



Energy  
Transitions  
Commission

# Building decarbonisation workshop 5: strategies to reduce embodied carbon

July 16<sup>th</sup>

# Agenda

- **Introduction to embodied carbon**
  - Understanding what embodied carbon is
  - The embodied carbon challenge
- **New buildings: key levers to reduce embodied carbon in the production and construction stages**
  - Decarbonising material inputs (e.g., cement and steel)
  - Material efficiency and building design levers
- **Existing buildings: the balance of embodied vs operational carbon in retrofits**
  - Carbon payback from retrofits
  - Retrofit vs rebuild debate
- **Barriers and implementation**



# 1. Introduction to embodied carbon



# 1.1 Understanding embodied carbon



# Embodied carbon accounts for ~13% of annual emissions; 7% of this relates to buildings, with a further 26% of annual emissions relating to operational energy use

## Global emissions by sector, 2022

GtCO<sub>2</sub>

Total buildings emissions 12.3 GtCO<sub>2</sub>

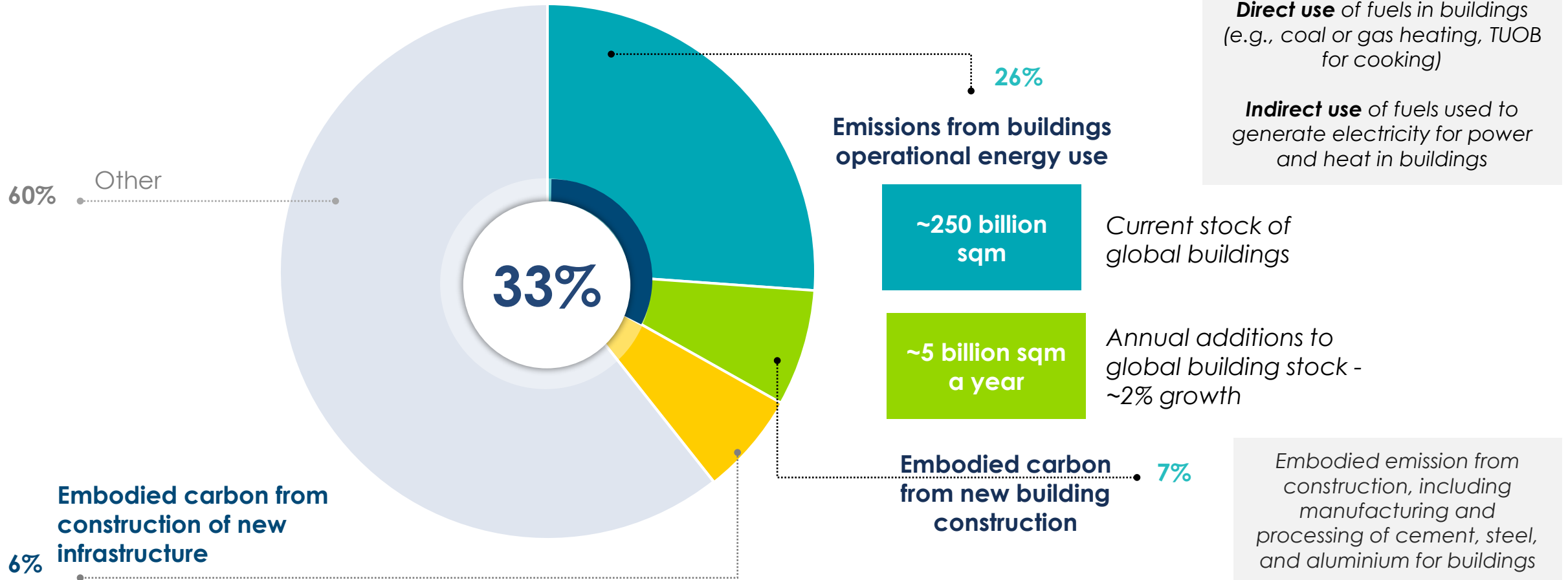

Note this shows annual carbon flows as opposed to stock. Direct GHG emissions are from sources that are owned or controlled by the reporting entity (e.g. on-site fuel combustion – scope 1) whereas indirect GHG emissions are a consequence of the activities of the reporting entity but occur at sources owned or controlled by another entity (e.g. electricity purchased from the grid – scope 2)  
 Sources: IEA (2023), The energy efficiency policy package: key catalyst for building decarbonisation and climate action

# Half of embodied carbon emissions are from the construction of buildings, the other half from infrastructure

## Global embodied emissions by sector, 2022

GtCO<sub>2</sub>

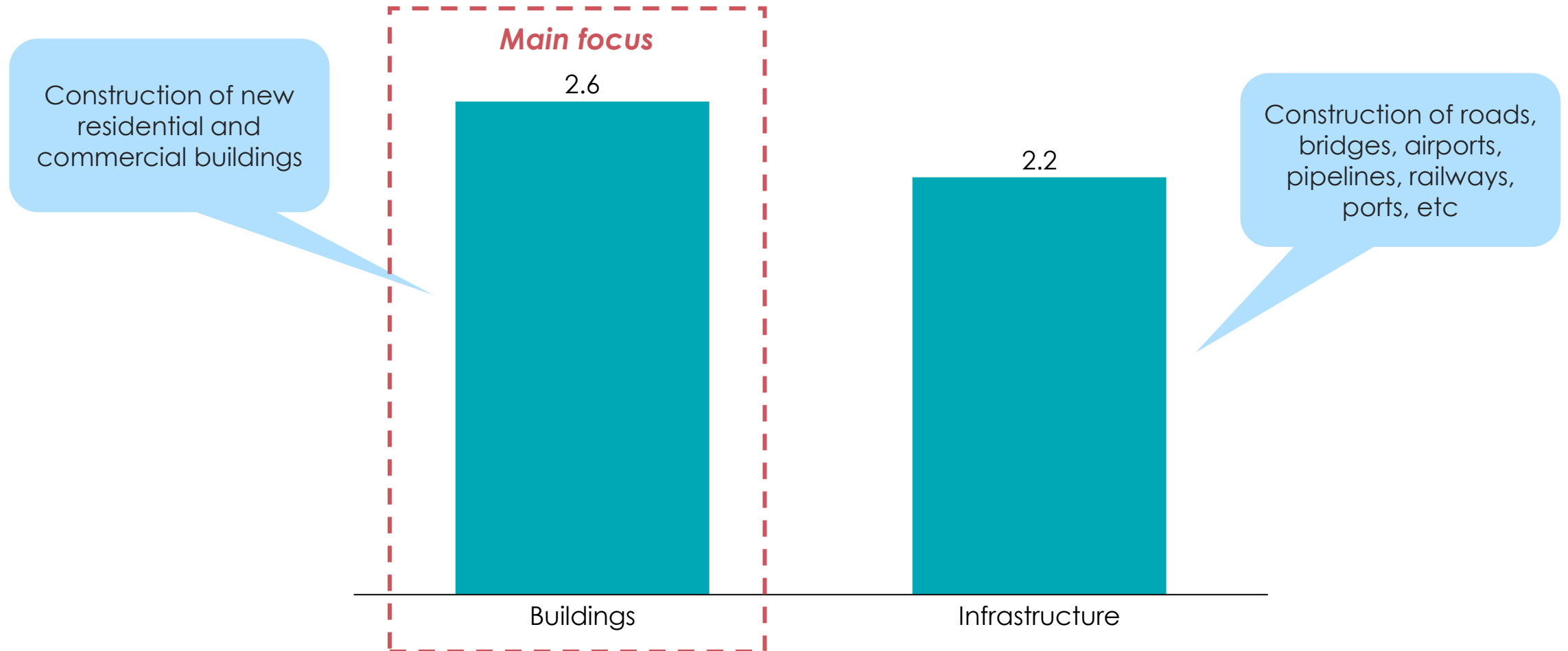

Note this shows annual carbon flows as opposed to stock. Direct GHG emissions are from sources that are owned or controlled by the reporting entity (e.g. on-site fuel combustion – scope 1) whereas indirect GHG emissions are a consequence of the activities of the reporting entity but occur at sources owned or controlled by another entity (e.g. electricity purchased from the grid – scope 2)  
Sources: IEA (2023), *The energy efficiency policy package: key catalyst for building decarbonisation and climate action*

# Embodied carbon refers to the emissions from any process relating to the construction, maintenance and demolishing of buildings

## Sources of embodied and operational carbon emissions across building life cycle stages

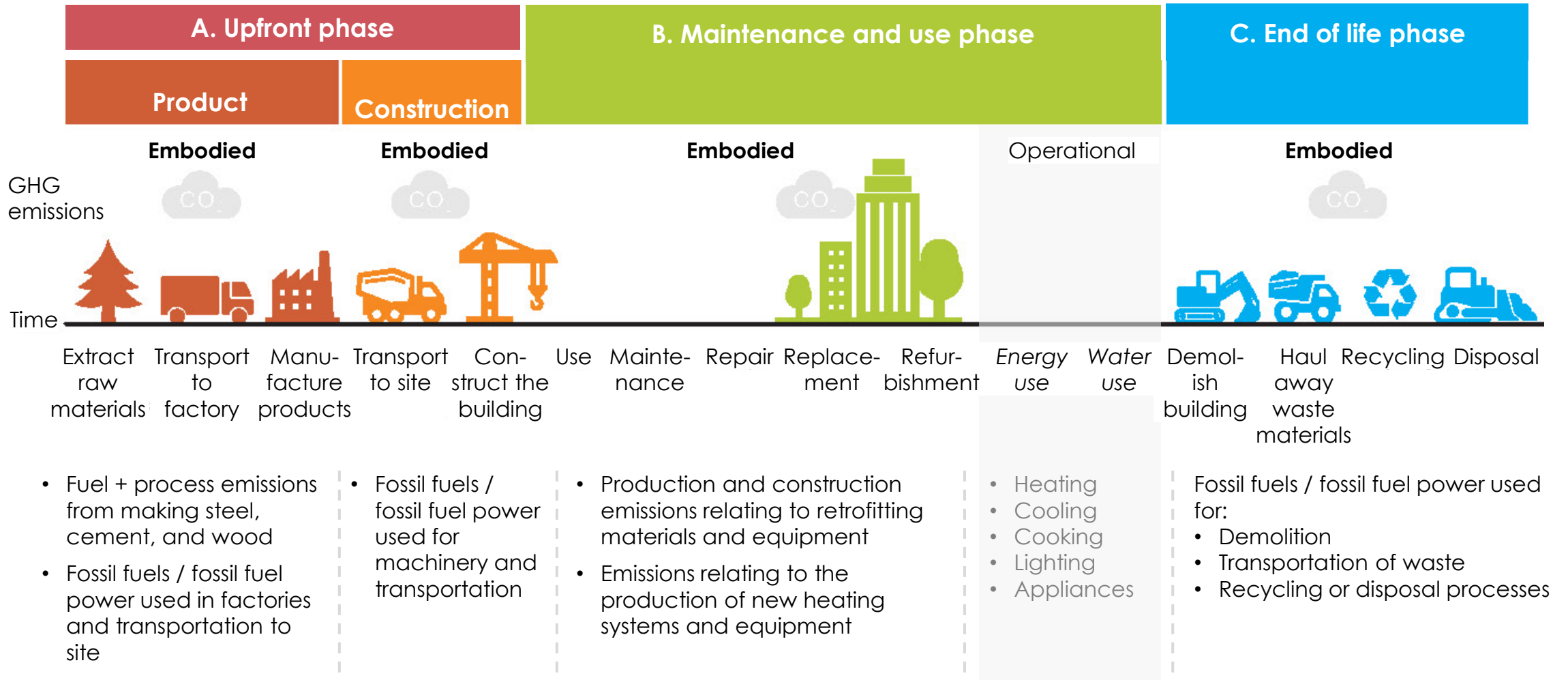

Source: New Buildings Institute, *Embodied Carbon*

# Embodied emissions are one-off bursts at a few points in a building's lifecycle, while operational emissions are long-term and recur every year

## Whole life carbon emissions over time

kgCO<sub>2</sub>e/m<sup>2</sup>, average distribution across 6 buildings in Europe

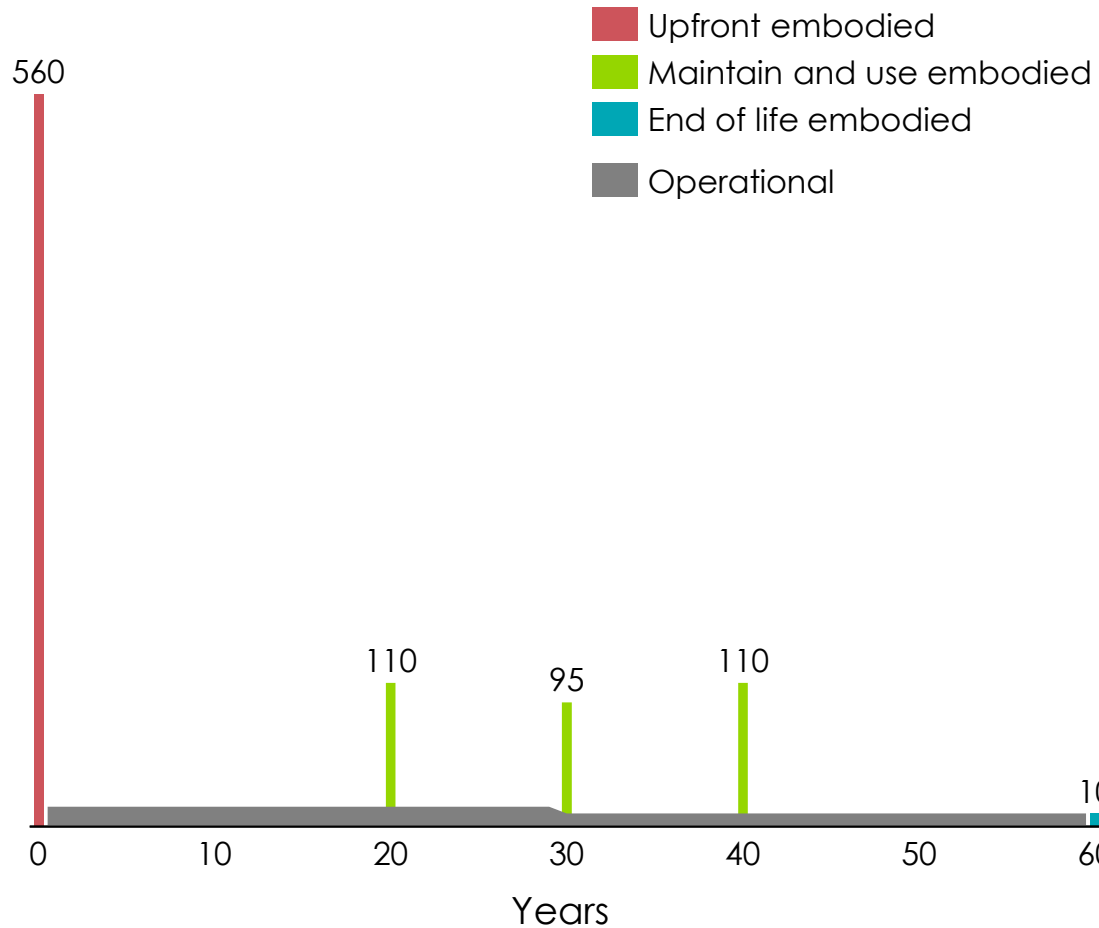

## Share of total lifecycle emissions over 60 years

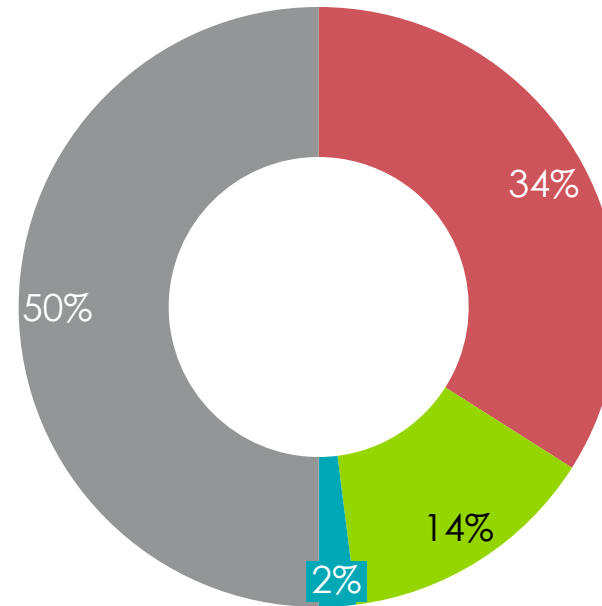

- There is a lack of data and **no consensus** on embodied carbon baselines today
- Case studies suggest that embodied carbon accounts for **~50% of a building's lifecycle emissions**
- The **vast majority** of embodied carbon emissions are in the **upfront stages (product + construction)**

Source: WBCSD & Arup (2023), *Net-zero buildings Halving construction emissions today*; RMI (2023), *Embodied Carbon 101: Building Materials*

# A Upfront embodied carbon arises from the production of building materials and the construction of the 4 building layers

## 1. Structure

### Superstructure

- Frame
- Upper floors
- Roof
- Stairs and ramps

### Substructure

- Foundations
- Retaining walls
- Lowest level slab

### Common materials

- Structural concrete
- Reinforced concrete
- Tile
- Steel
- Aluminium
- Timber (wood)

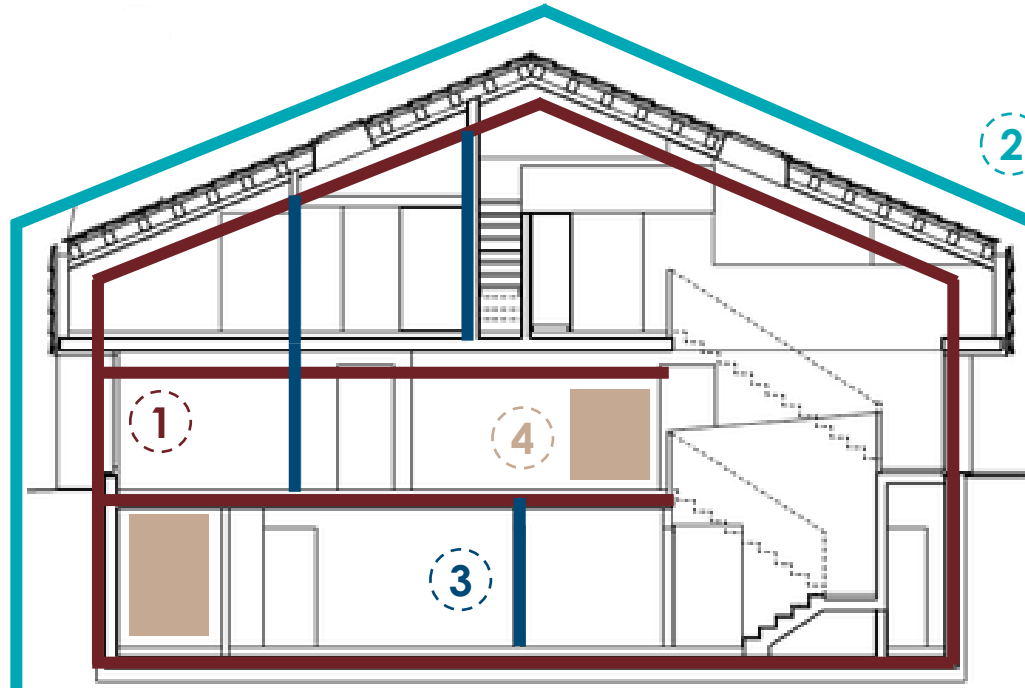

## 2. Skin (façade)

### External walls

- Concrete
- Metal panels
- Brick

### Windows

- Glass
- Frame (metal or timber)

### External doors

- Metal or timber

## 3. Space plan (partitions and finishes)

### Internal walls and doors

- Metal or timber

### Wall, floor and ceiling finishes

- Paint
- Tile
- Wallpaper
- Wood panelling

## 4. Services

### Mechanical (HVAC)

- Metal
- Refrigerant

### Electrical (wiring, lighting)

- Metal
- Glass

### Public health (drainage, pipework, plumbing)

- Metal, plastic

# A Cement, concrete and steel account for 95% of embodied emissions, and the rest comes from other materials such as bricks, aluminium and glass

## Cement and steel contribution to global construction material carbon impact

%

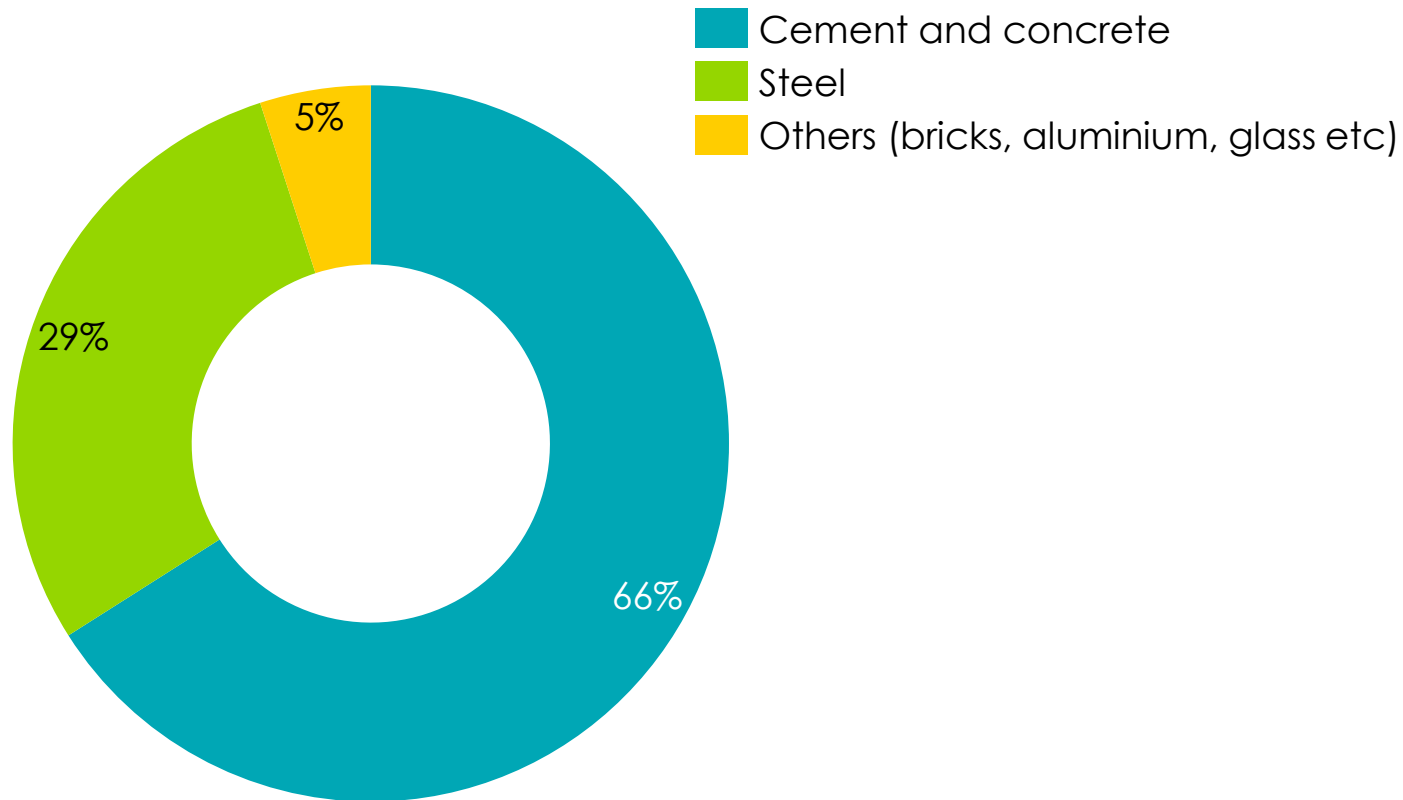

- Concrete and steel are the **predominant structural construction materials** by a large margin
- Developers should explore and develop alternative, low-carbon materials
- Generally, whatever material developers are using, they should aim to **use as little of it as possible**



# A A building's structure accounts for over half of its embodied emissions, driven by steel and cement/concrete

## Estimated typical upfront embodied carbon distribution for a building in Europe

Total of 760 kgCO<sub>2</sub>e/m<sup>2</sup>; % share

Preliminary

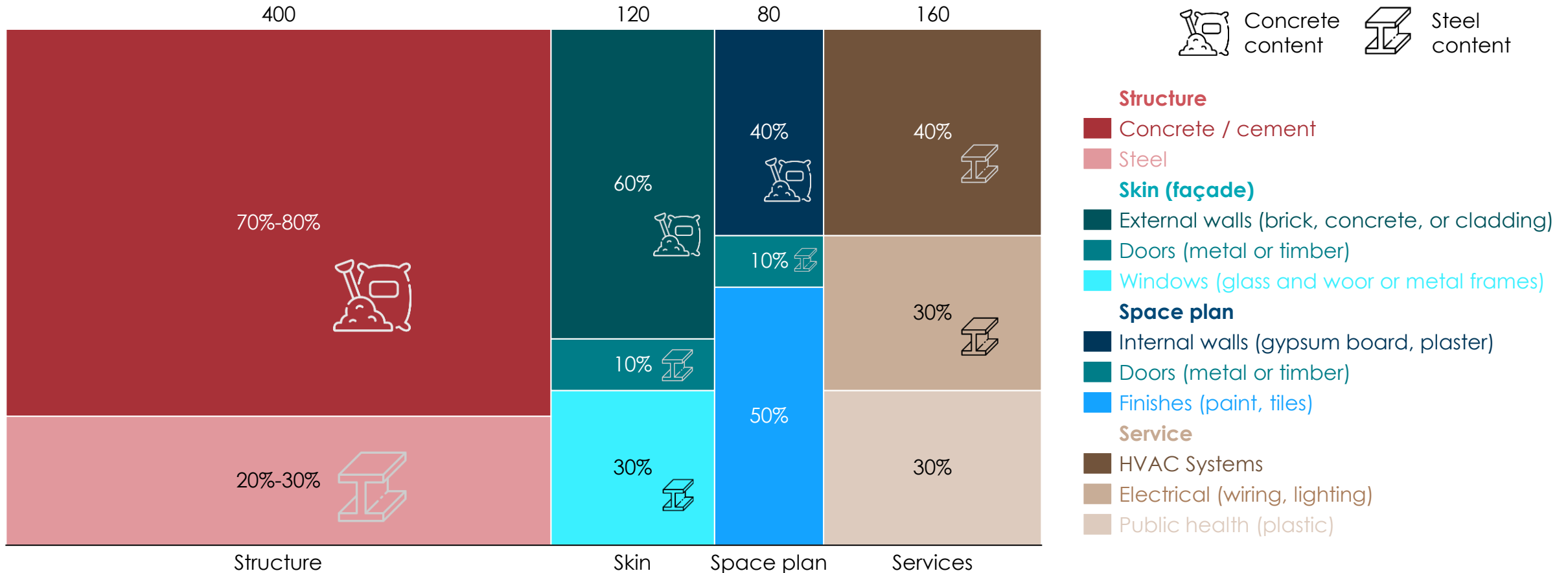

Source: Typical upfront embodied carbon and the building layers spilt from WBCSD & Arup (2023), *Net-zero buildings Halving construction emissions today*; material split from literature review, including ArchDaily (2021), *How to Approach Embodied Carbon Reduction within an Architectural Project*

## **B** Maintenance and use emissions come from retrofitting with new materials and products as building layers having different replacement cycles

### Building layer life cycles

Element life cycle over 60 years

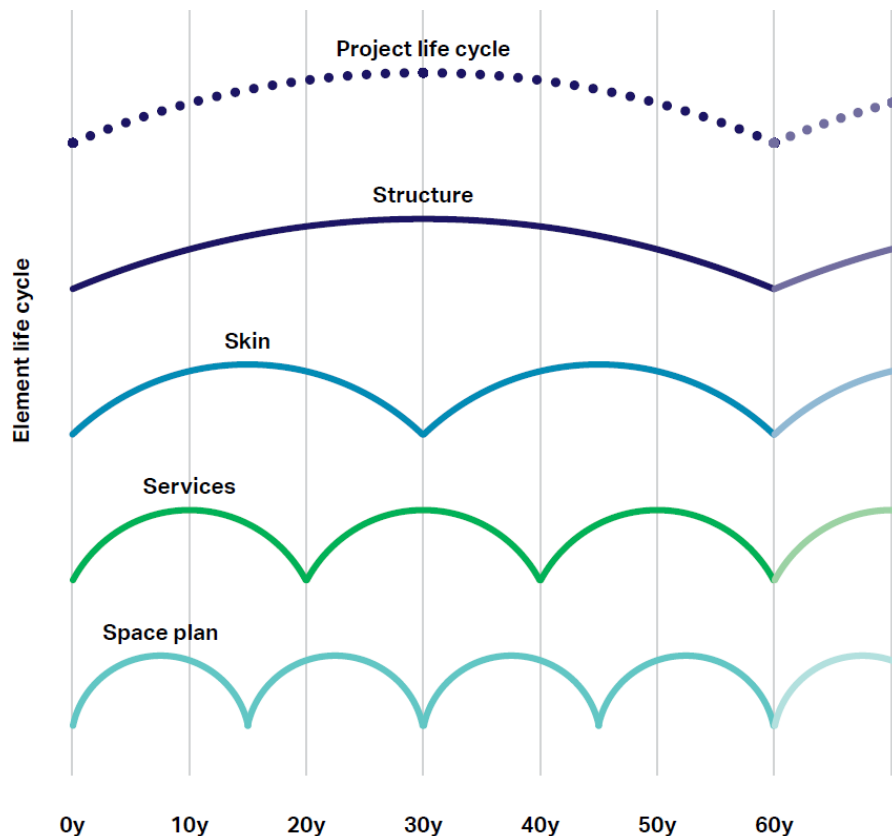

#### Structure (30-60 years)

The construction of a building, which involves the structural skeleton

#### Skin (30-35 years)

The outside layers of a building such as the façade, including windows, surface material and insulation

Main focus

#### Services (20-30 years)

Smart energy systems, lighting and air conditioning that support the internal climate in a building

#### Space plan (10-30 years)

The materials used for compartmentalisation: suspended ceilings, raised floors and all internal surface finishes

## B The embodied carbon from retrofitting building fabric will, however, result in emission savings from avoided operational energy use

### Illustration of the balance between embodied carbon and operational carbon from insulation

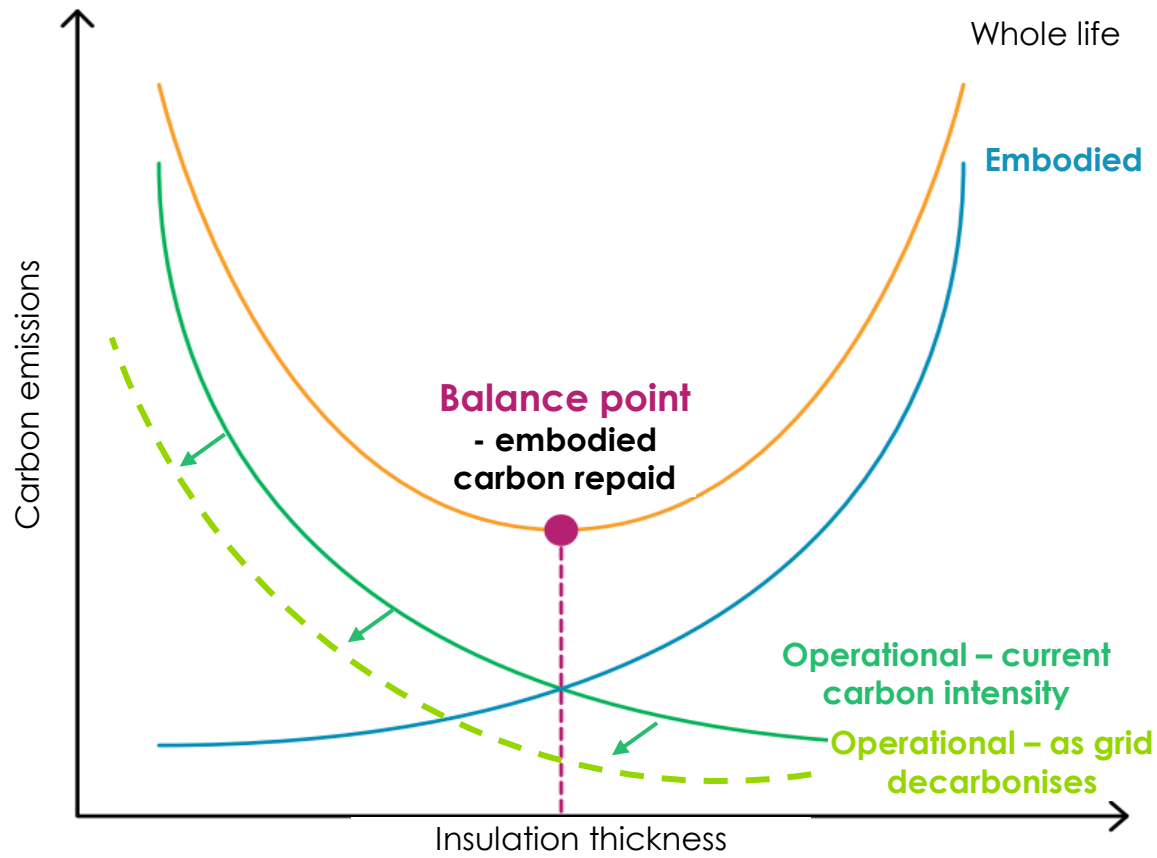

- Understanding the net lifetime carbon from retrofitting requires weighing up the **embodied carbon** and the avoided **operational emissions**
- Beyond the **balance point**, further insulation will have a negative net impact on carbon emissions
- The **balance point** will shift over time, as **operational emissions** are decarbonised – creating trickier trade-offs for retrofit
- The **balance point** will vary depending on the building and type of intervention

To be explored in Section 3: how long does it take the embodied carbon of retrofits to be paid back in operational energy savings?

# C End of life embodied carbon involves emissions from several processes, including demolition, deconstruction, transportation, and recycling or disposal

Where is embodied carbon produced at end of life?

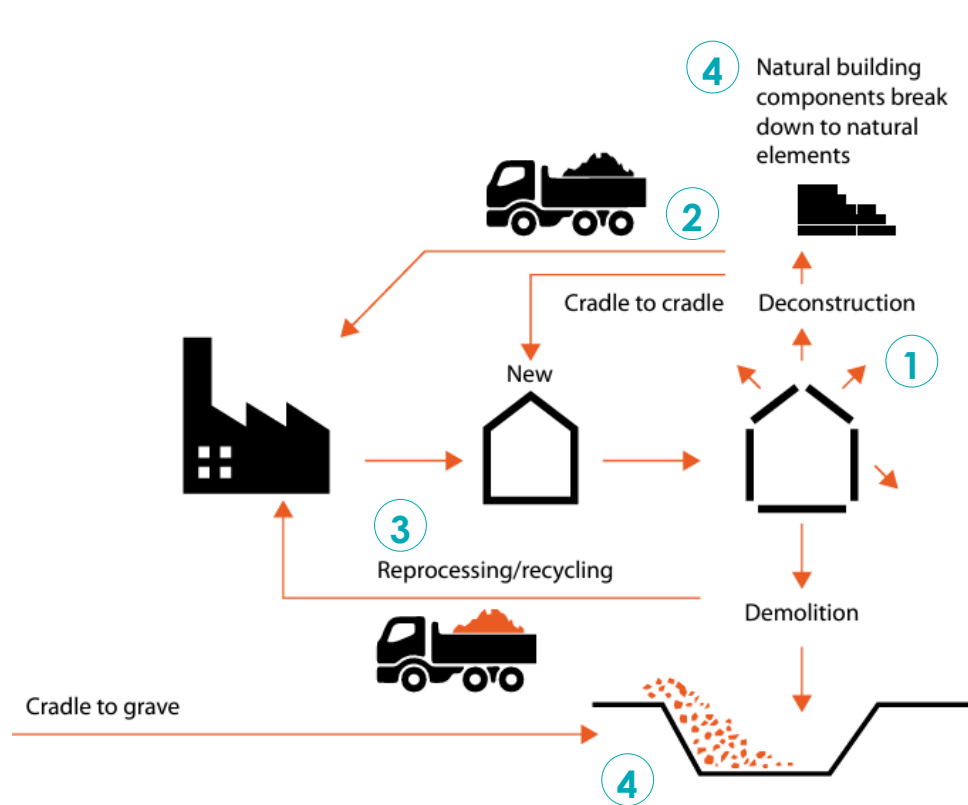

## 1 Demolition/Deconstruction

- Energy consumption from machinery and equipment used (e.g., excavators)

## 2 Transportation

- From fuel combustion in material transport vehicles (e.g., transport debris to reprocessing centre)

## 3 Reprocessing/Recycling

- Energy consumption from machinery and equipment used at recycling facilities (e.g., granulators)

## 4 Waste Processing/Disposal

- Combustion emissions from incineration (e.g., timber)
- Methane emissions from decomposing (e.g., timber)
- Emissions from landfill operations

**End of life stage generally has a low impact**, however, when using biogenic material (e.g., timber), the disposal will release a part or all of the sequestered carbon to the atmosphere depending of the end of life scenario considered

# 1.2 The embodied carbon challenge



# Embodied carbon: construction of new buildings

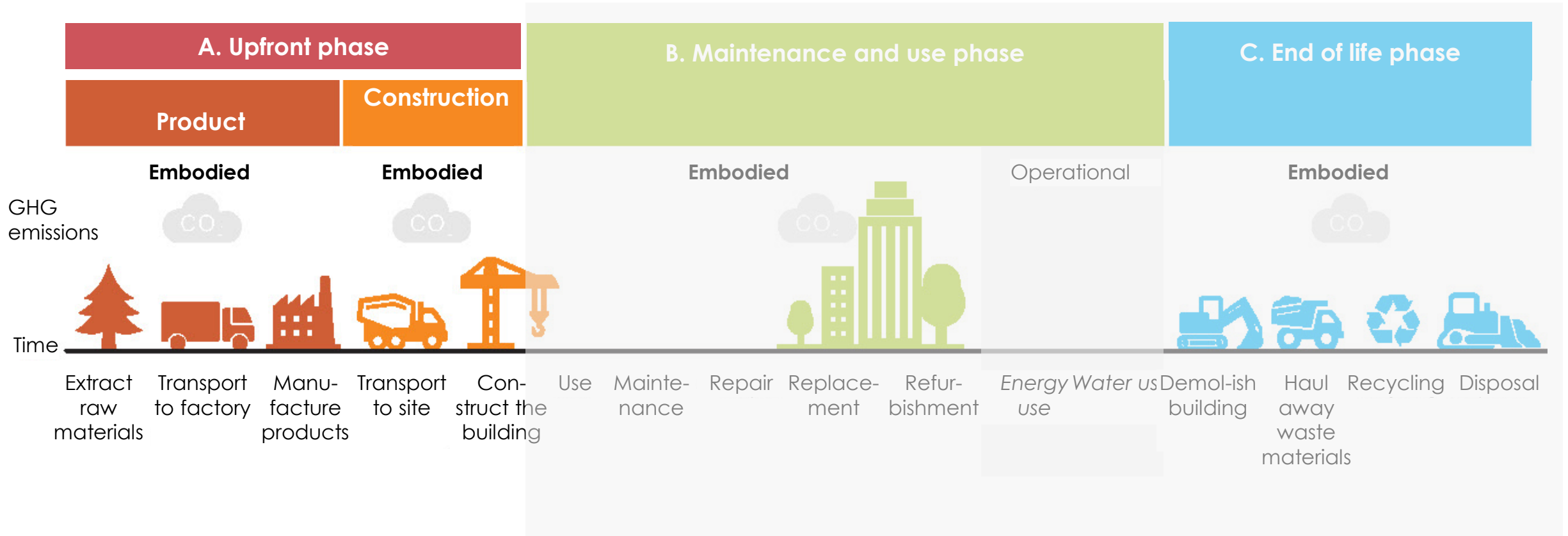

Source: New Buildings Institute, *Embodied Carbon*

# Global floor area is set to more than double to 2050, creating significant demands for material inputs; global concrete and cement use set to increase 45% by 2050

## Evolution of global floor area

2022-2050; Billion m<sup>2</sup>; IEA NZE Scenario

- Other middle and low income countries
- China
- High income countries

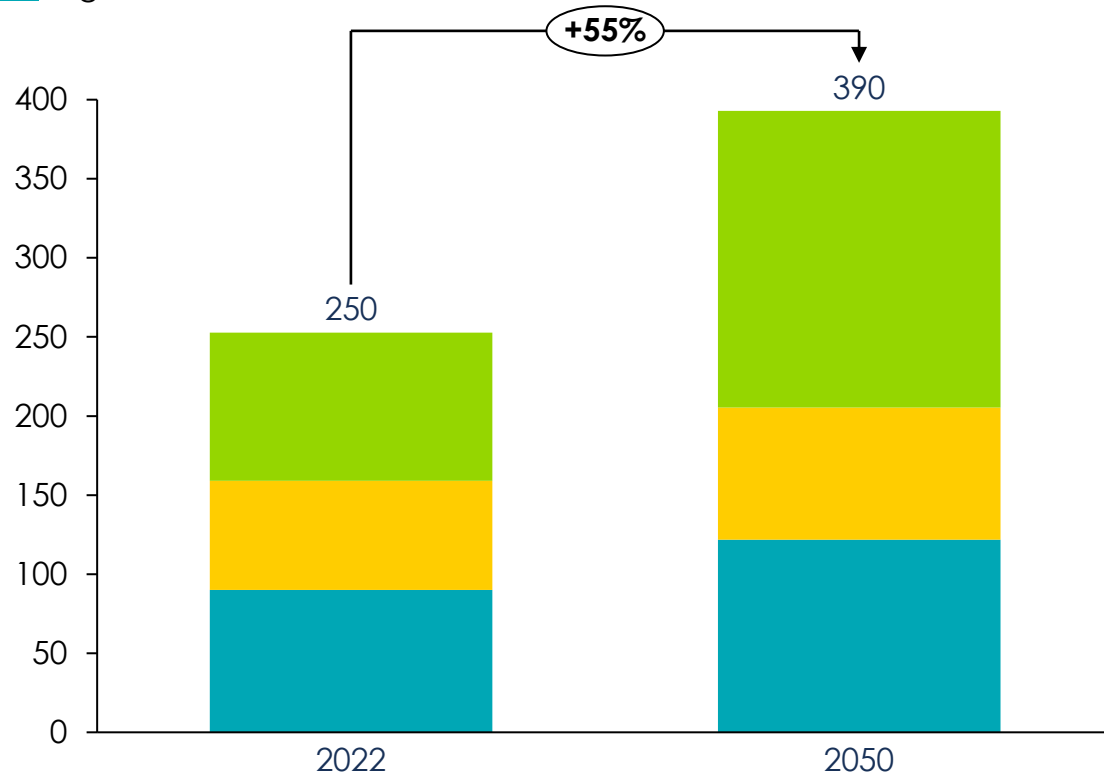

## Global concrete & cement demand, 2020 – 2050

Gt/yr in a no action scenario

- Concrete
- Cement

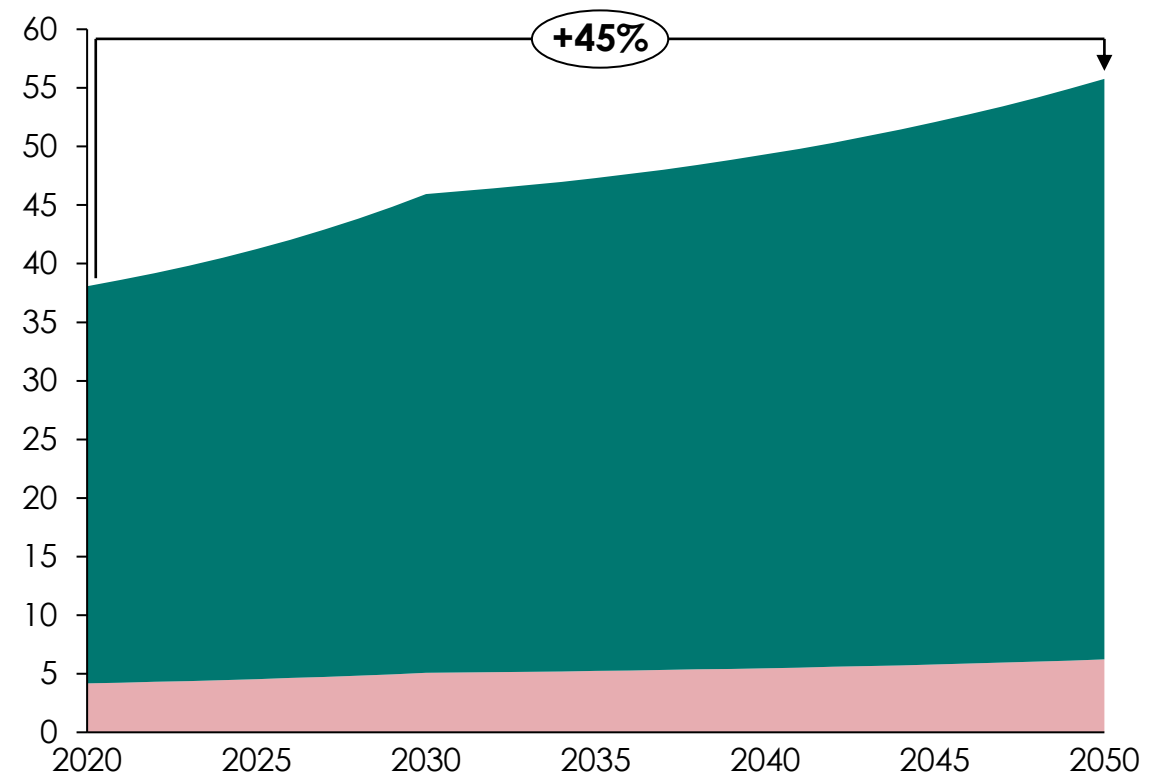

# At today's embodied carbon intensity, total emissions from construction of new buildings could amount to ~75 Gt CO<sub>2</sub>e, or 40% of the remaining carbon budget

Global cumulative embodied emissions, 2023 – 2050, compared to remaining carbon budget

Gt CO<sub>2</sub>e

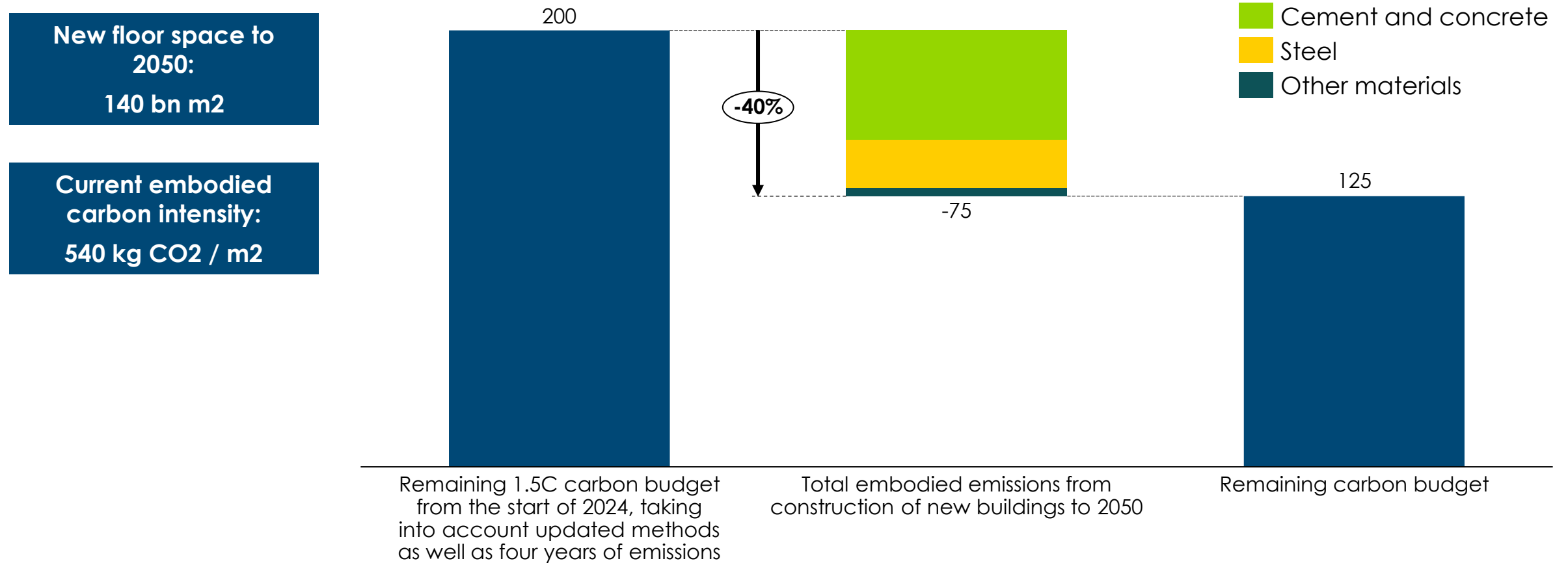

Sources: Systemiq analysis for ETC (2024); IEA for global floor area and emissions; Forster et. al (2024) *Indicators of Global Climate Change 2023: annual update of key indicators of the state of the climate system and human influence*

Note: current embodied carbon intensity calculated from 2.6GtCO of annual embodied carbon emissions, divided by 4.6bn m<sup>2</sup> of new floor space



# Embodied carbon: retrofit of existing buildings

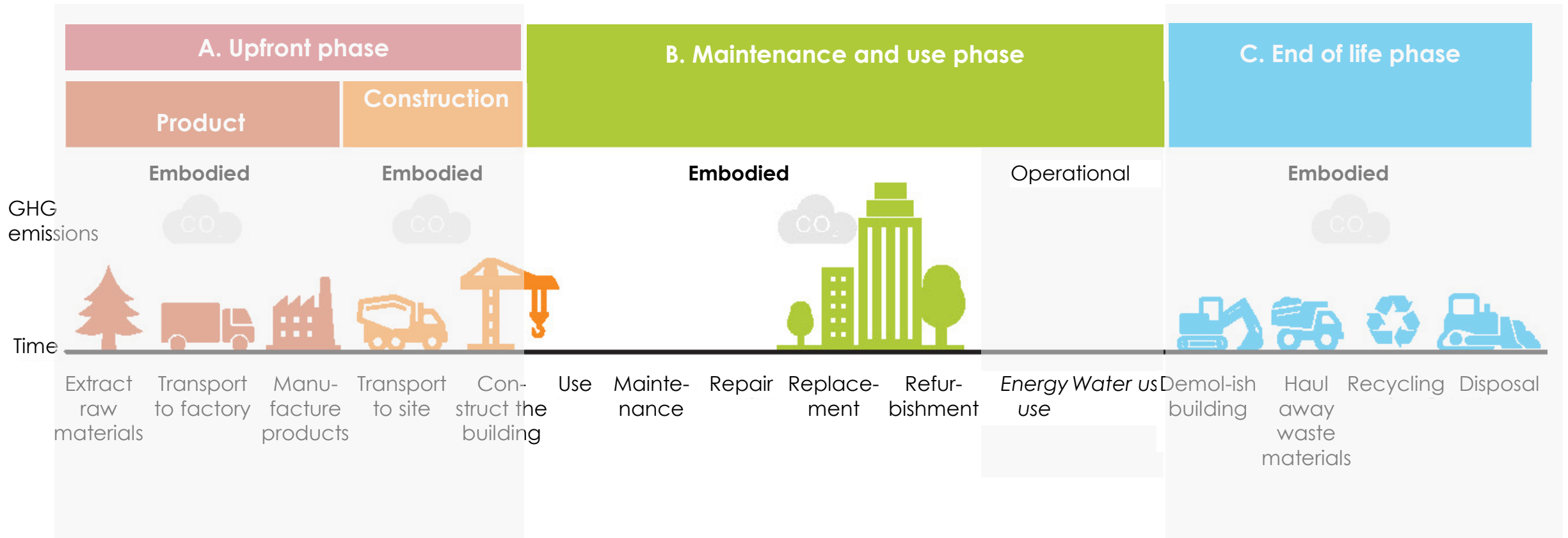

Source: New Buildings Institute, *Embodied Carbon*

# Embodied emissions from the retrofit of existing buildings are set to significantly rise, as heating systems are electrified and energy efficiency improvements are prioritised

## Share of buildings that are zero-carbon-ready, existing buildings

% share of existing building stock; IEA NZE Scenario

■ Retrofitted ■ No retrofit

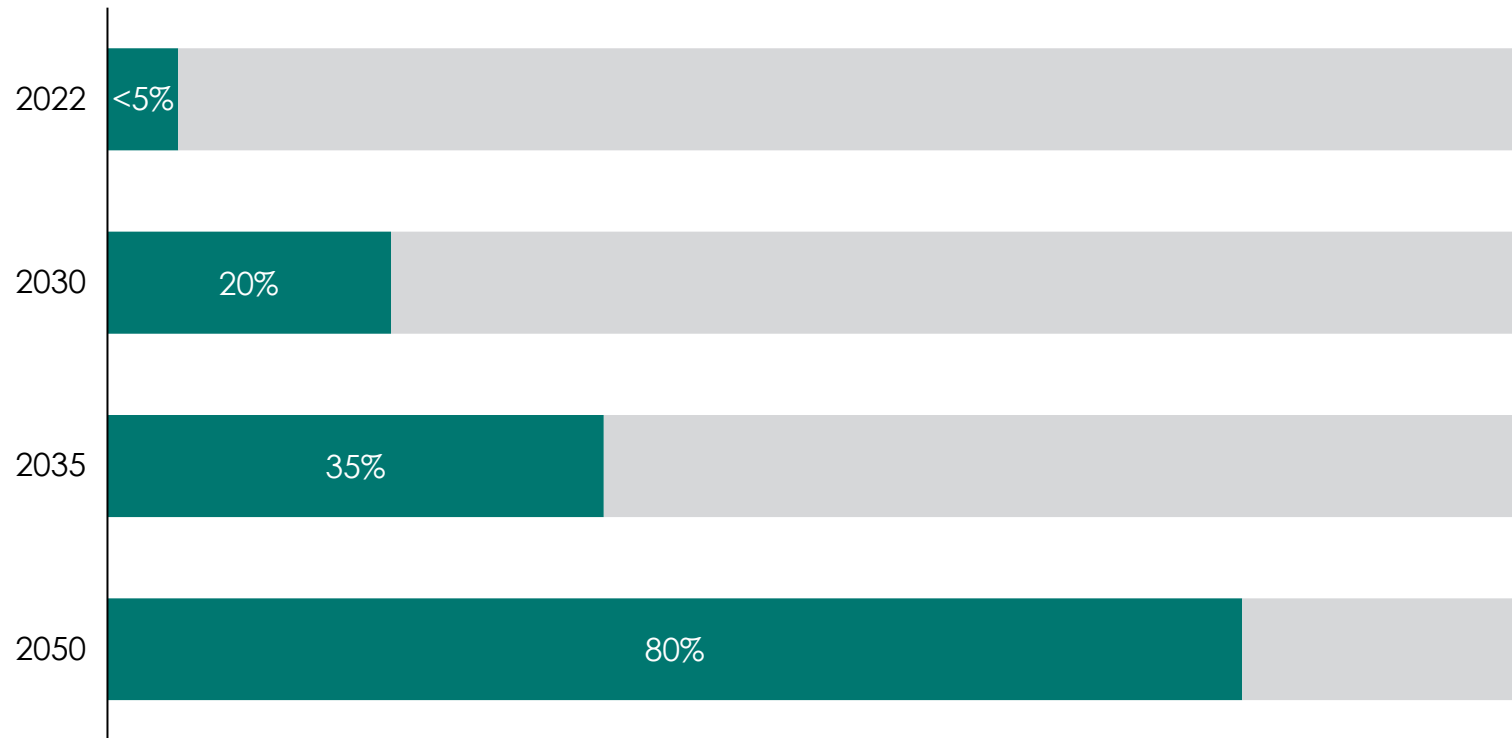

Retrofit to a **zero-carbon ready building** involves actions to:

- Improve energy efficiency (e.g., insulation)
- Removal of fossil fuel heating and cooking systems



# At today's embodied carbon intensity, total emissions from retrofitted existing buildings could amount to ~20 Gt CO<sub>2</sub>e, or 10% of the remaining carbon budget

Global cumulative embodied emissions, 2023 – 2050, compared to remaining carbon budget

Gt CO<sub>2</sub>e

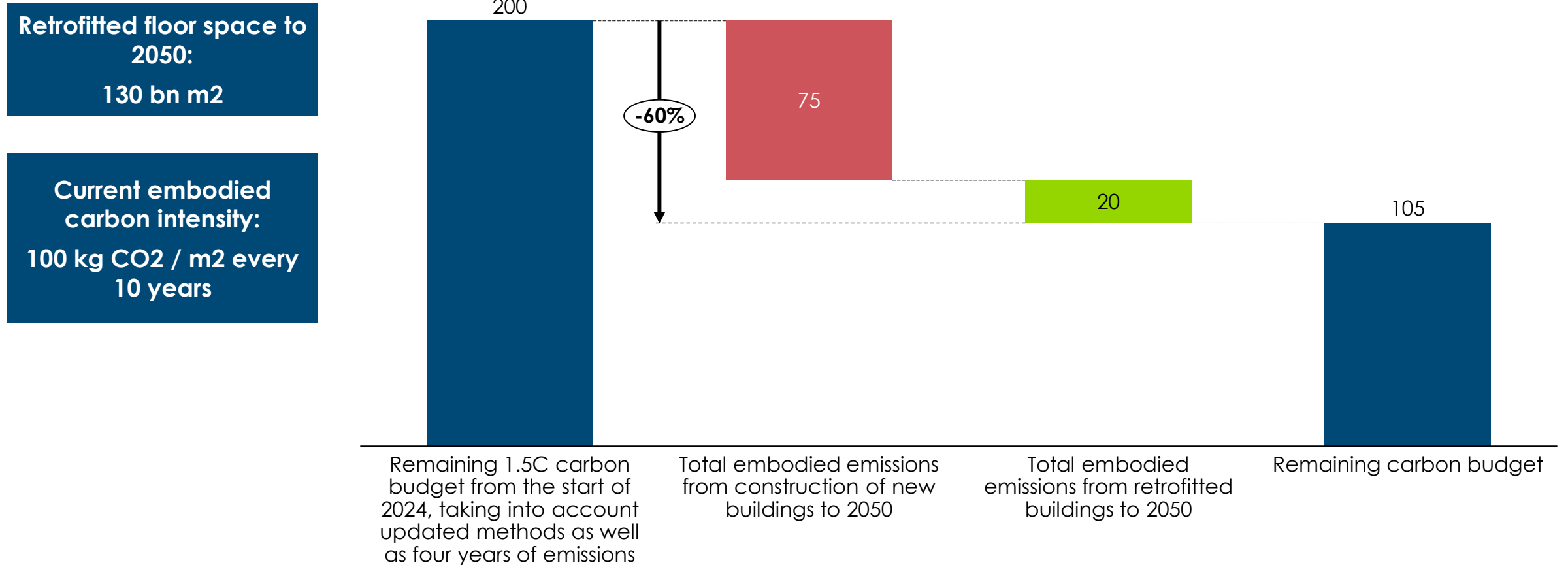

Sources: Systemiq analysis for ETC (2024); IEA for global floor area and emissions  
Note: current embodied carbon intensity based on European data from WBCSD & Arup (2023), *Net-zero buildings Halving construction emissions today*; RMI (2023), *Embodied Carbon 101: Building Materials*

# Embodied carbon: end of life of old building stock

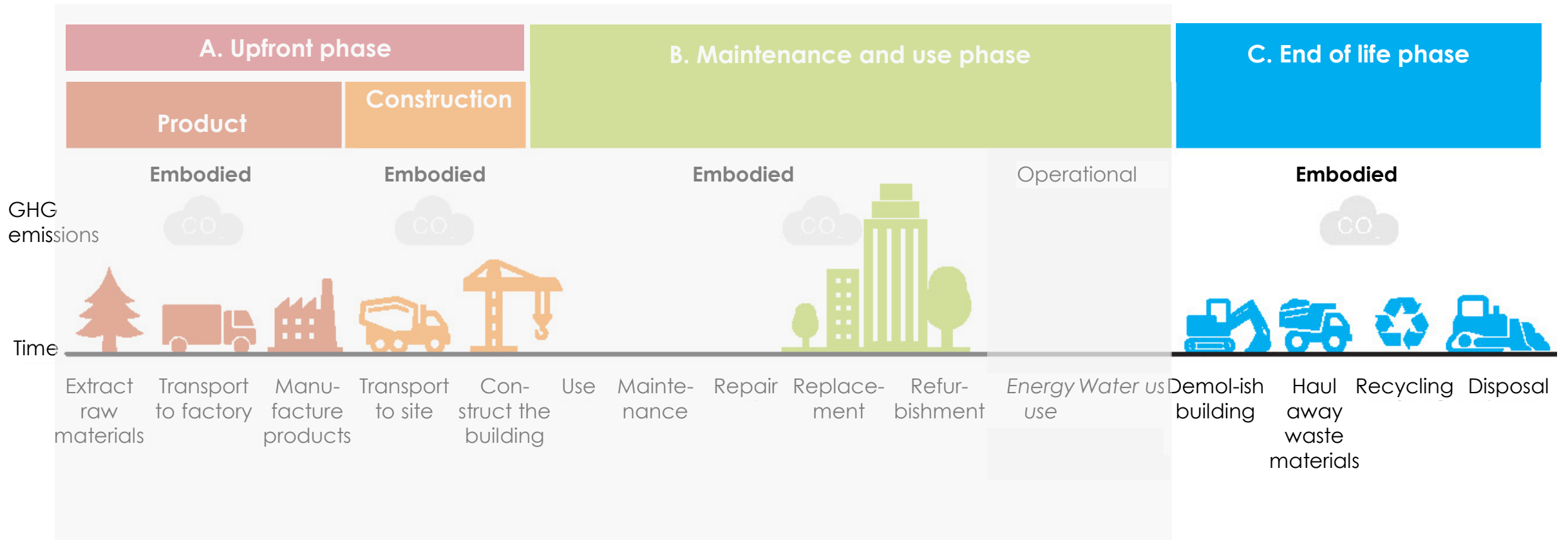

Source: New Buildings Institute, *Embodied Carbon*

# A significant share of buildings, especially in Europe, are over 60 years old and could reach end of life over the coming decades

## Distribution of population by built year of residential building, select European countries

% of total, 2021

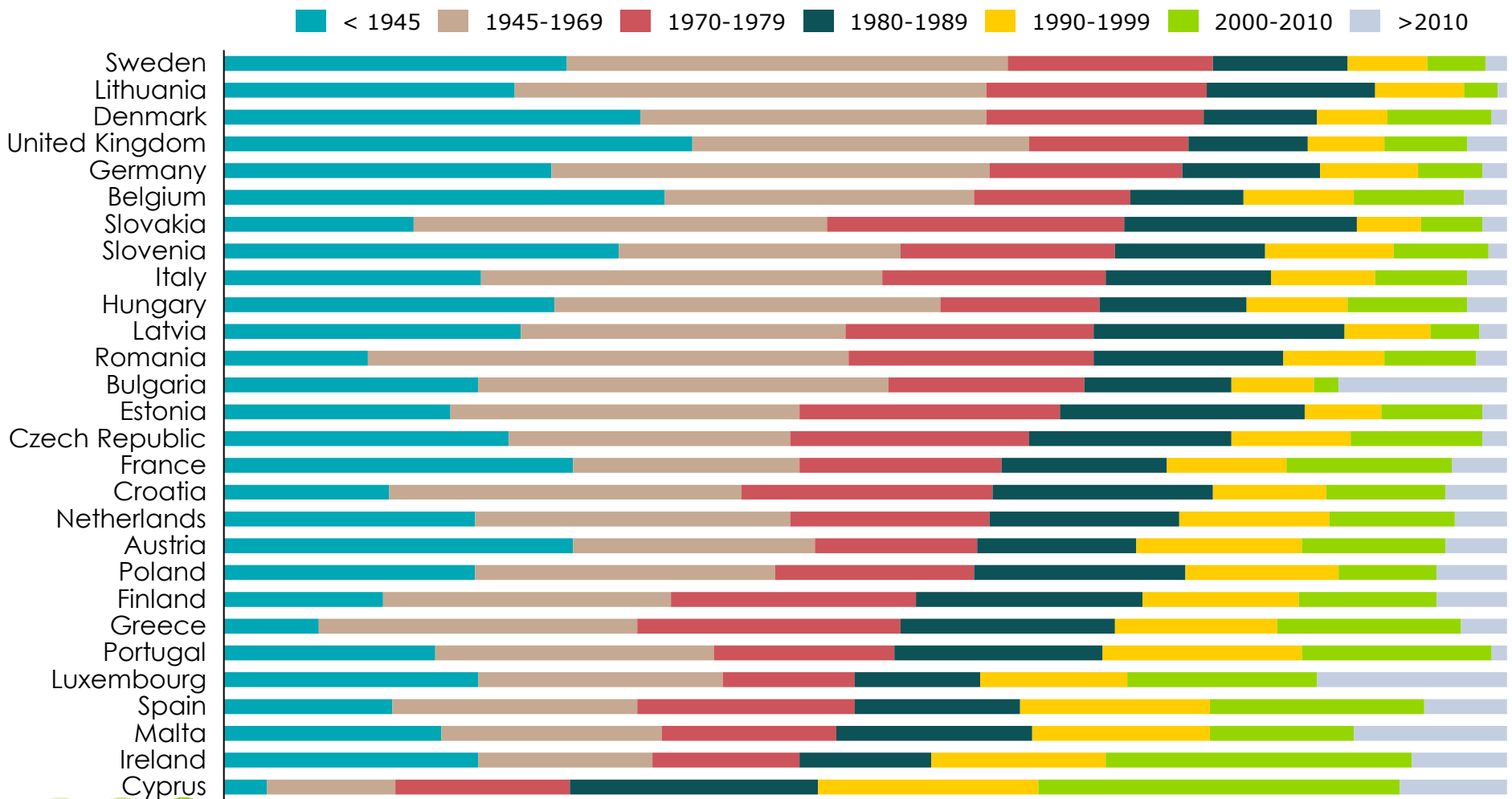

**25% of homes were built before 1945**

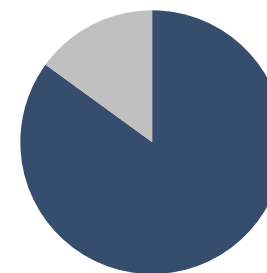

Source: European Commission, Directorate-General for Energy for Europe

# Embodied emissions from end of life are a much smaller challenge; if 10% of existing buildings are demolished, this would contribute <1GtCO2 at today's carbon intensities

Global cumulative embodied emissions, 2023 – 2050, compared to remaining carbon budget

Gt CO2e

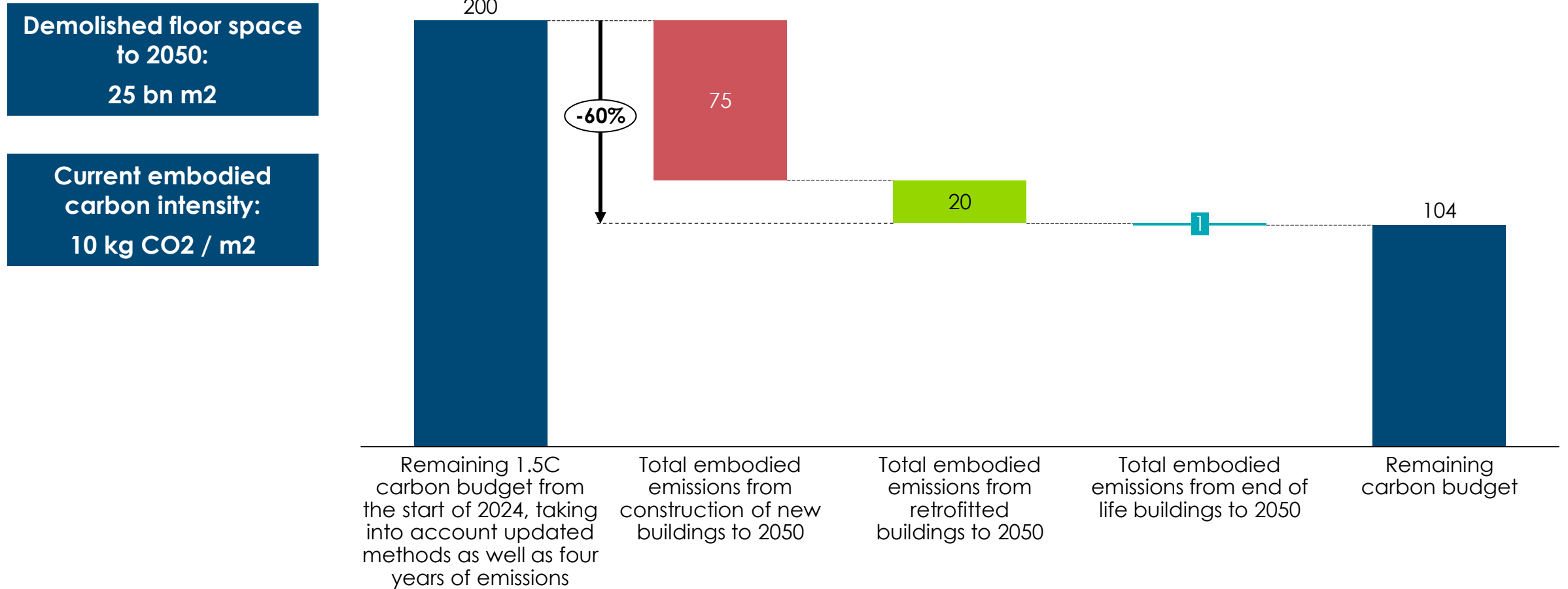

Sources: Systemiq analysis for ETC (2024); IEA for global floor area and emissions  
 Note: current embodied carbon intensity based on European data from WBCSD & Arup (2023), *Net-zero buildings Halving construction emissions today*; RMI (2023), *Embodied Carbon 101: Building Materials*



## 2. Decarbonising upfront embodied carbon



# Embodied carbon: decarbonising material inputs

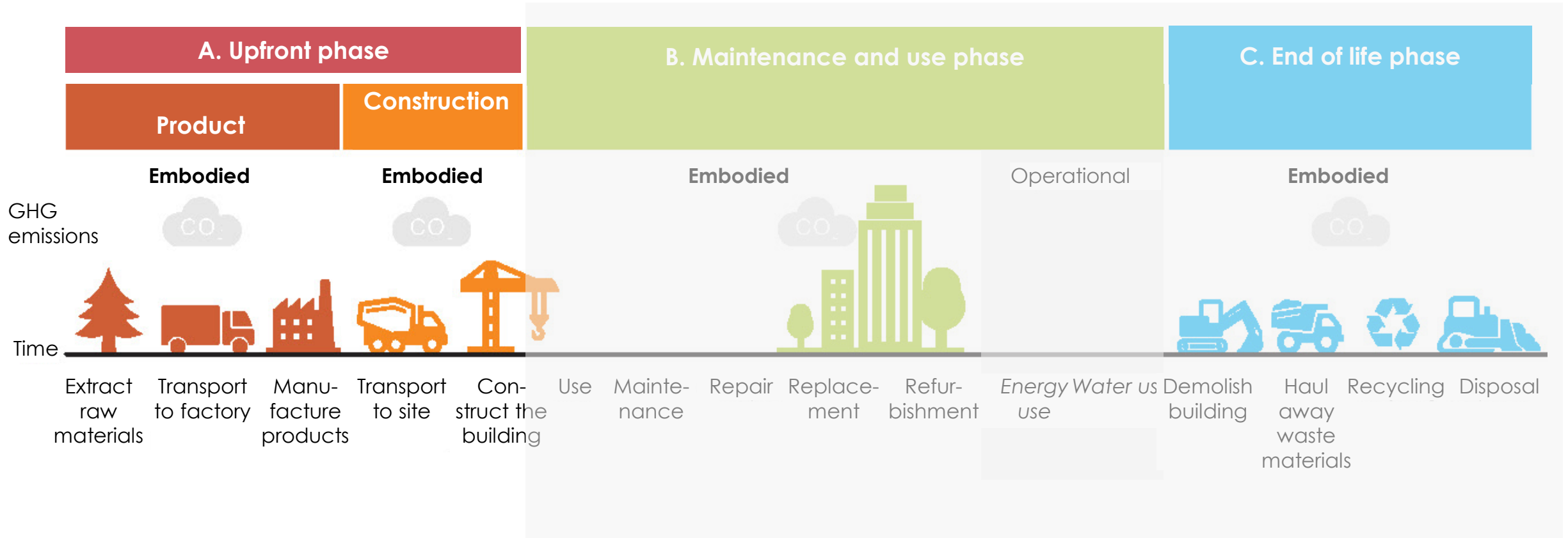

Source: New Buildings Institute, *Embodied Carbon*

# Building materials differ in terms of their carbon intensity, depending on production fuels, required temperatures and process chemistry

## Embodied carbon of common building materials

kg CO<sub>2</sub>/kg; global average estimates based on public literature, but emissions will depend on **fuels and region** of production

✘ Global average  
 ■ Global range

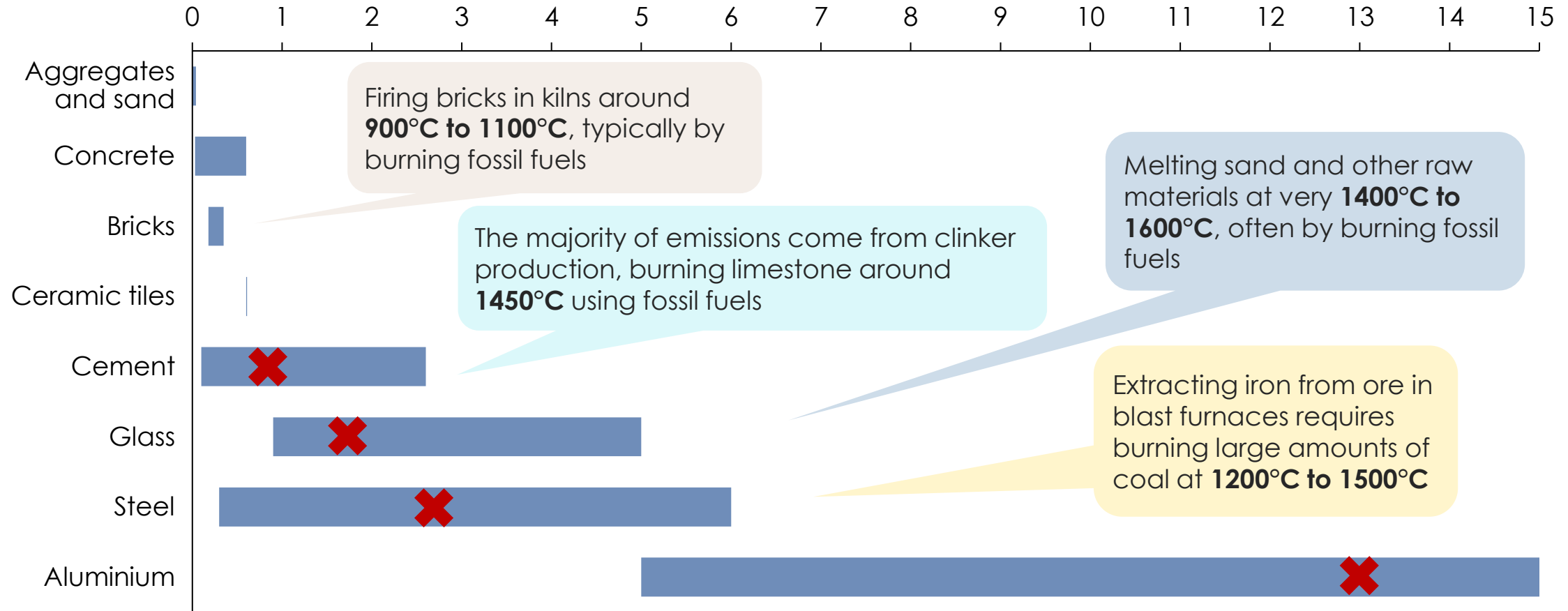

# There are many different types of steel for a variety of uses across sectors, with different embodied carbon; rebar is the most commonly used in buildings

Pre-read only

Type of steel	Embodied carbon kgCO <sub>2</sub> e/kg	Description	Main uses
Rebar	1.99	Reinforcing steel used in reinforced concrete	Building and infrastructure construction
Plate	2.46	Flat steel sheet rolled on a hot rolling mill	Pipes, shipbuilding, offshore structures, heavy metal structures
Electro-galvanised steel	3.03	Thin layer of zinc or nickel to provide corrosion resistance	Buildings – wall and roofing elements, lighting Cars
Welded pipe	2.78	Flat plate steel coil, welded into tube	Transport fluids (e.g., gases, oil, water)
Tinplate	2.85	Electro plating with tin	Food cans, industrial packaging



Source: Jones and Hammond (2019), *Inventory of Carbon and Energy(ICE)*; GreenSpec, *Embodied Carbon & EPDs*  
Note: list not exhaustive

# The built environment accounts for all concrete use, whereas steel is much more widely used across other sectors

## Concrete and steel end-use by mass

% share

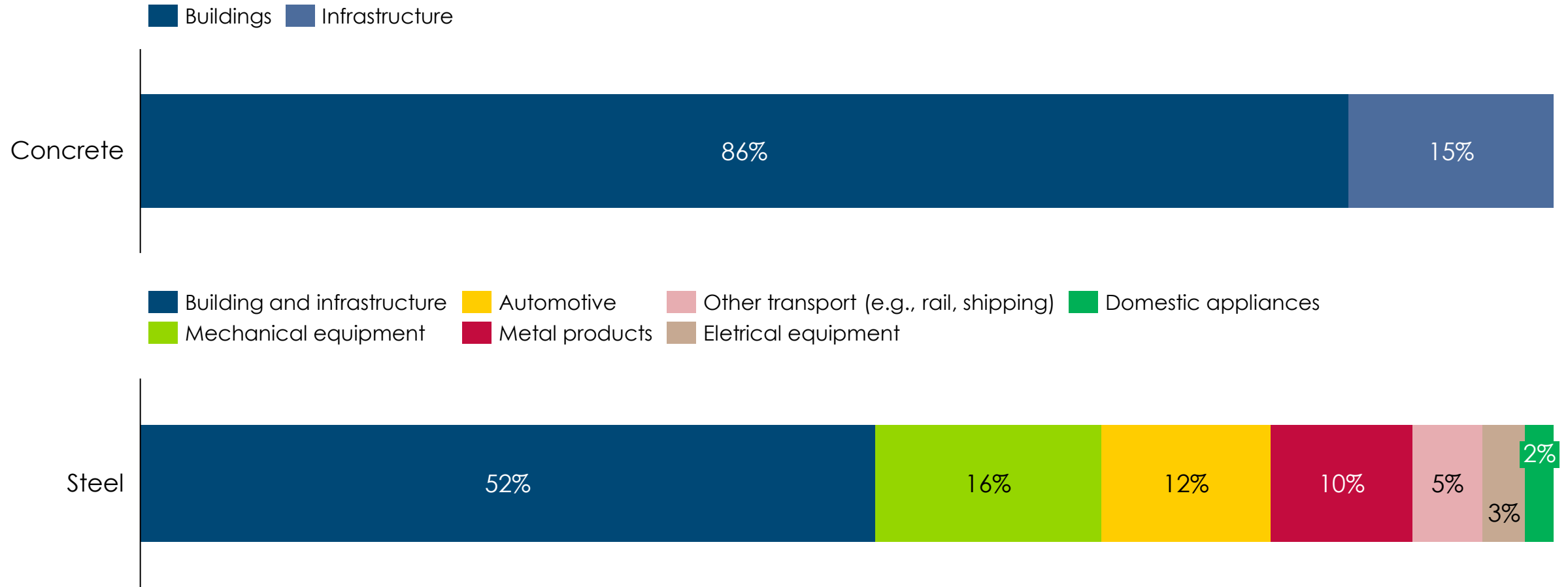

Source: Mission Possible Partnership (2023), *Making Net Zero Concrete and Cement Possible*; World Steel Association (2024), *World Steel in Figures 2024*  
Note: concrete numbers are an average of US, China, Europe and India; steel numbers are global

# Globally, cement and concrete account for around half of global building materials by mass and 66% of emissions; steel accounts for a further 29% of emissions

## Global building material use, 2017

% Share of 17.5 billion t

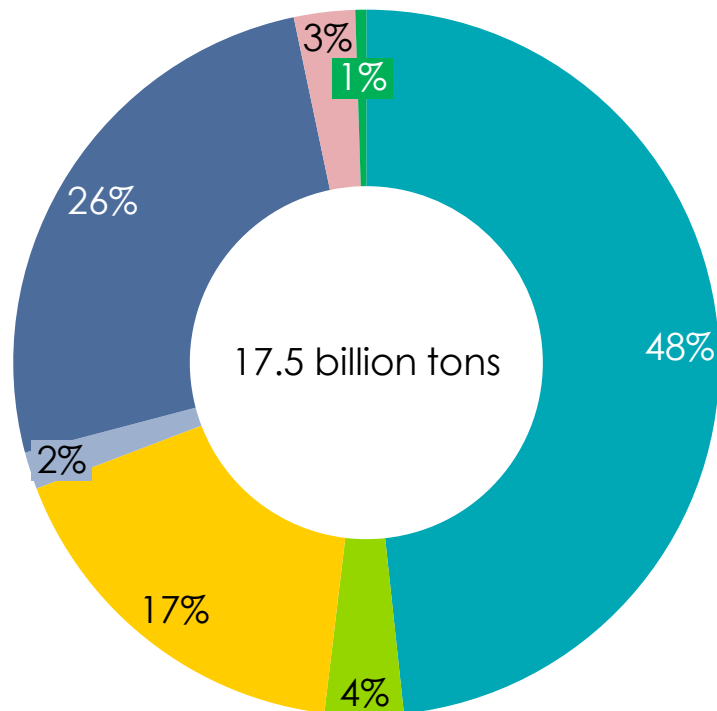

## Global construction material carbon impact

% of product phase embodied emissions

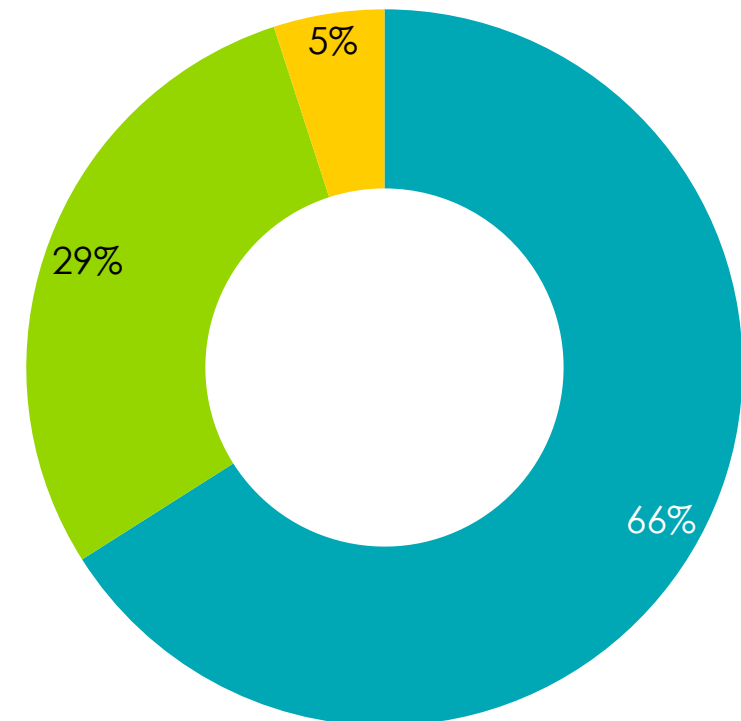
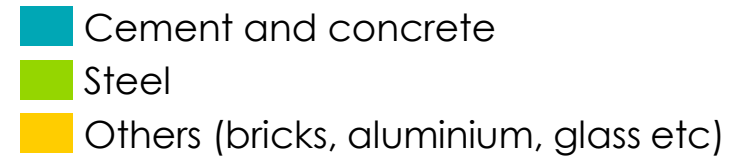

Source: Huang et al. (2020), *A Life Cycle Thinking Framework to Mitigate the Environmental Impact of Building Materials*; WBCSD & Arup (2023), *Net-zero buildings Halving construction emissions today*

# China accounts for over half of global material production and use; policies and regulation in China will therefore be critical to global progress

## Cement production by country, 2021

Top 10 largest producers, Mt

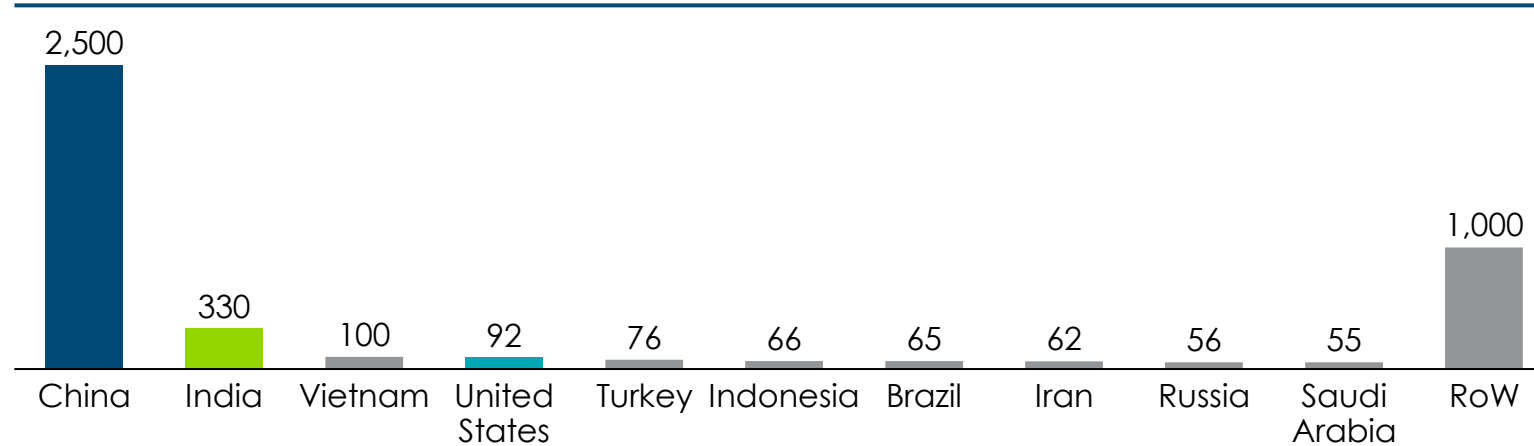

## Crude steel production by country, 2020

Mt

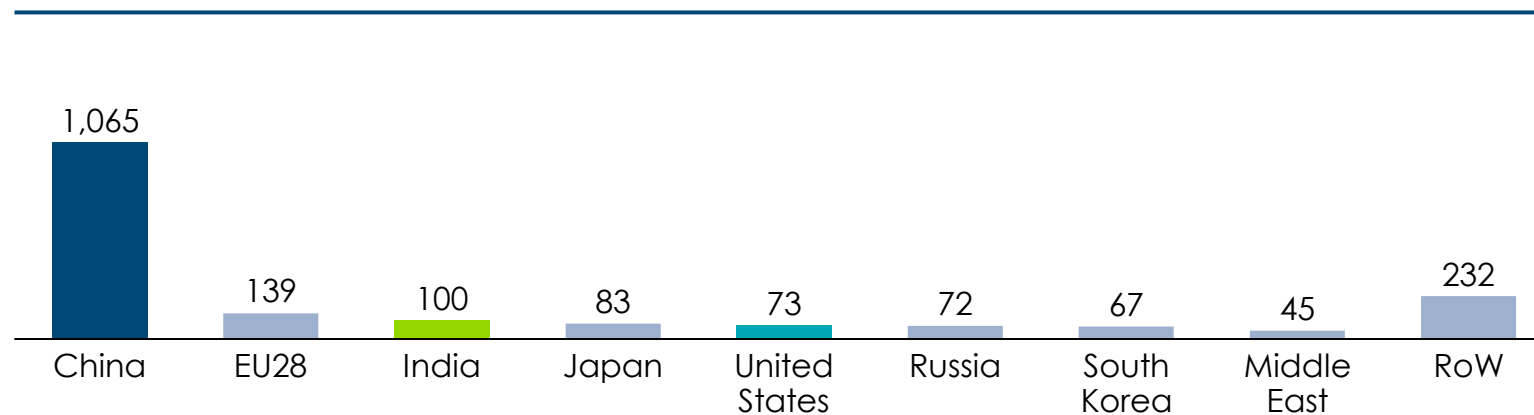

## Building material use by regions, 2017

% share

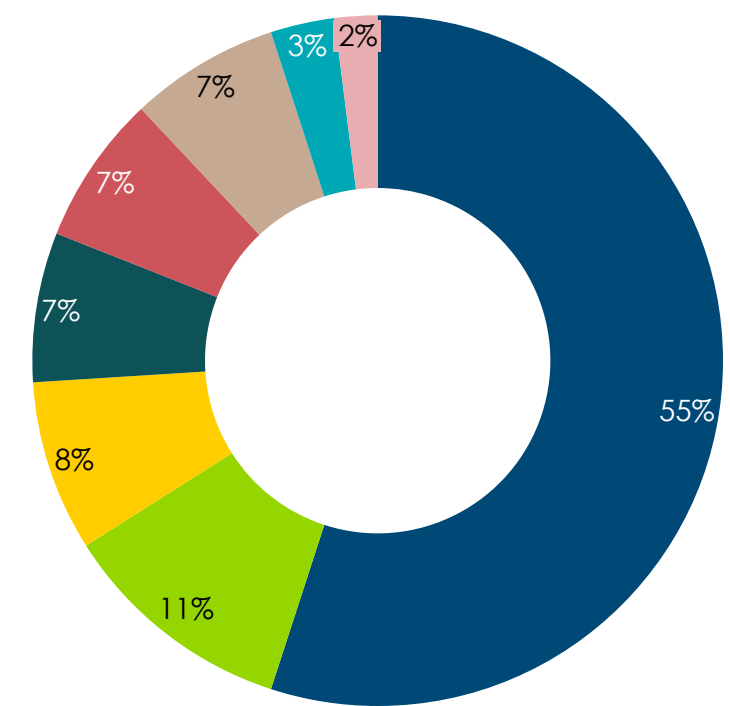
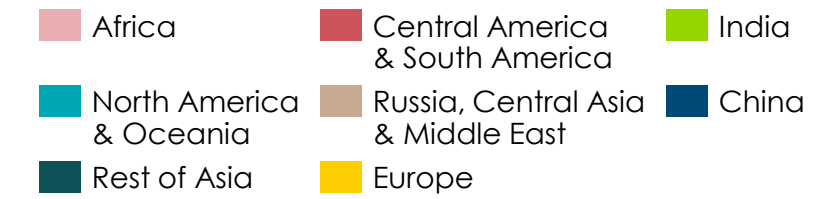

Source: Mission Possible Partnership (2023), *Making Net Zero Concrete and Cement Possible*; Mission Possible Partnership (2022), *Making Net Zero Steel Possible*; Huang et al. (2020), *A Life Cycle Thinking Framework to Mitigate the Environmental Impact of Building Materials*.

# In recent years, the MPP's sector transition strategies have challenged the belief that it was not possible to fully decarbonise steel, cement and concrete

- In recent years, the MPP's work has evidenced the technical and economic feasibility of reaching net zero in the so-called "hard to abate" industrial sectors
- The MPP sector transition strategies outline the set of technologies that exist today and possible transition pathways
- They evidence that it is possible to fully decarbonise material inputs for new buildings over the long-term



# The MPP strategies show that, while reducing demand is important, addressing process and production emissions is possible and the biggest emission reduction levers

## Cumulative GHG emissions between 2022 and 2050

Gt CO2

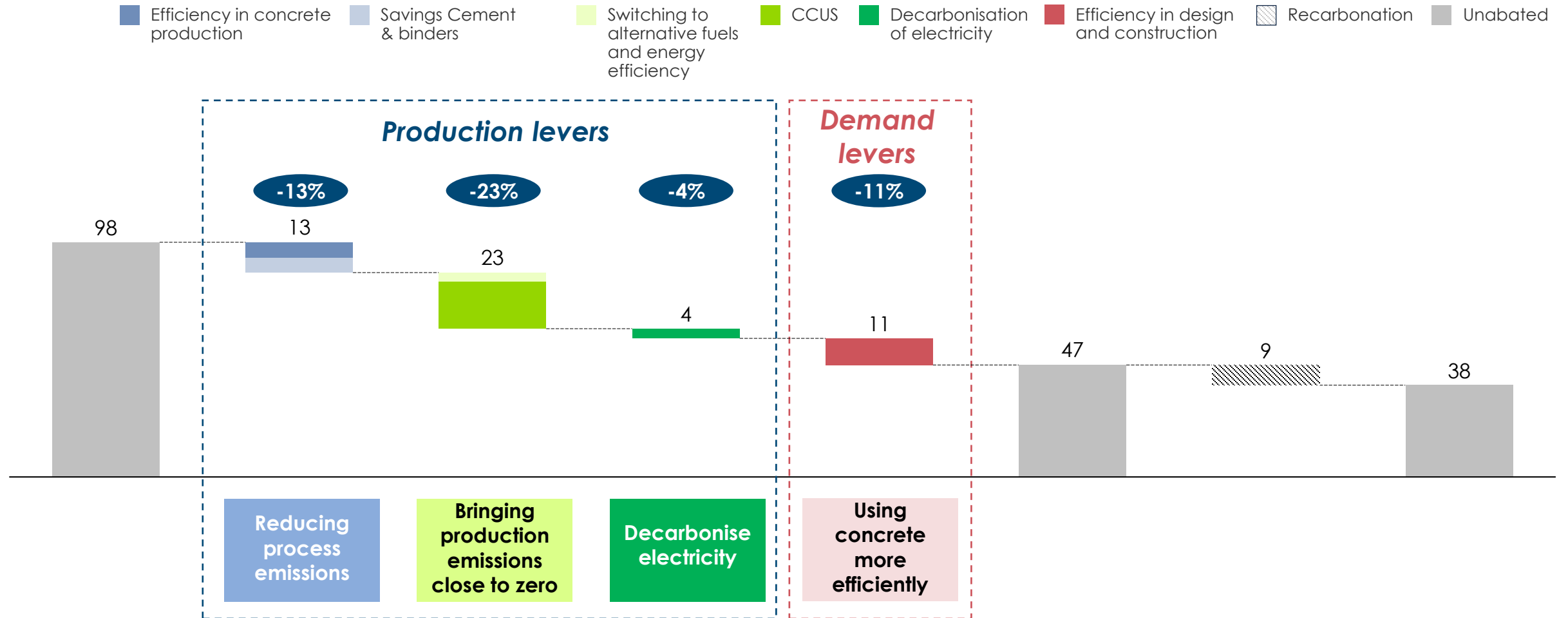

Notes: Includes scope 1 and 2 emissions. Scope 3 upstream would add approximately 3.8 Gt CO2e of cumulative emissions from 2022 to 2050. "Savings and binders" include switching to new binders. Decarbonisation of electricity involves electricity demand for kilns, grinders and carbon capture.  
 Source: Mission Possible Partnership (2023), *Making Net Zero Concrete and Cement Possible*



# However, scaling up decarbonisation technologies (e.g., CCUS) will not occur until the mid-2030s; material efficiency levers therefore need to play a critical role this decade

## Net zero, 1.5 degree aligned concrete and cement sector

GtCO<sub>2</sub> / year, after recarbonation

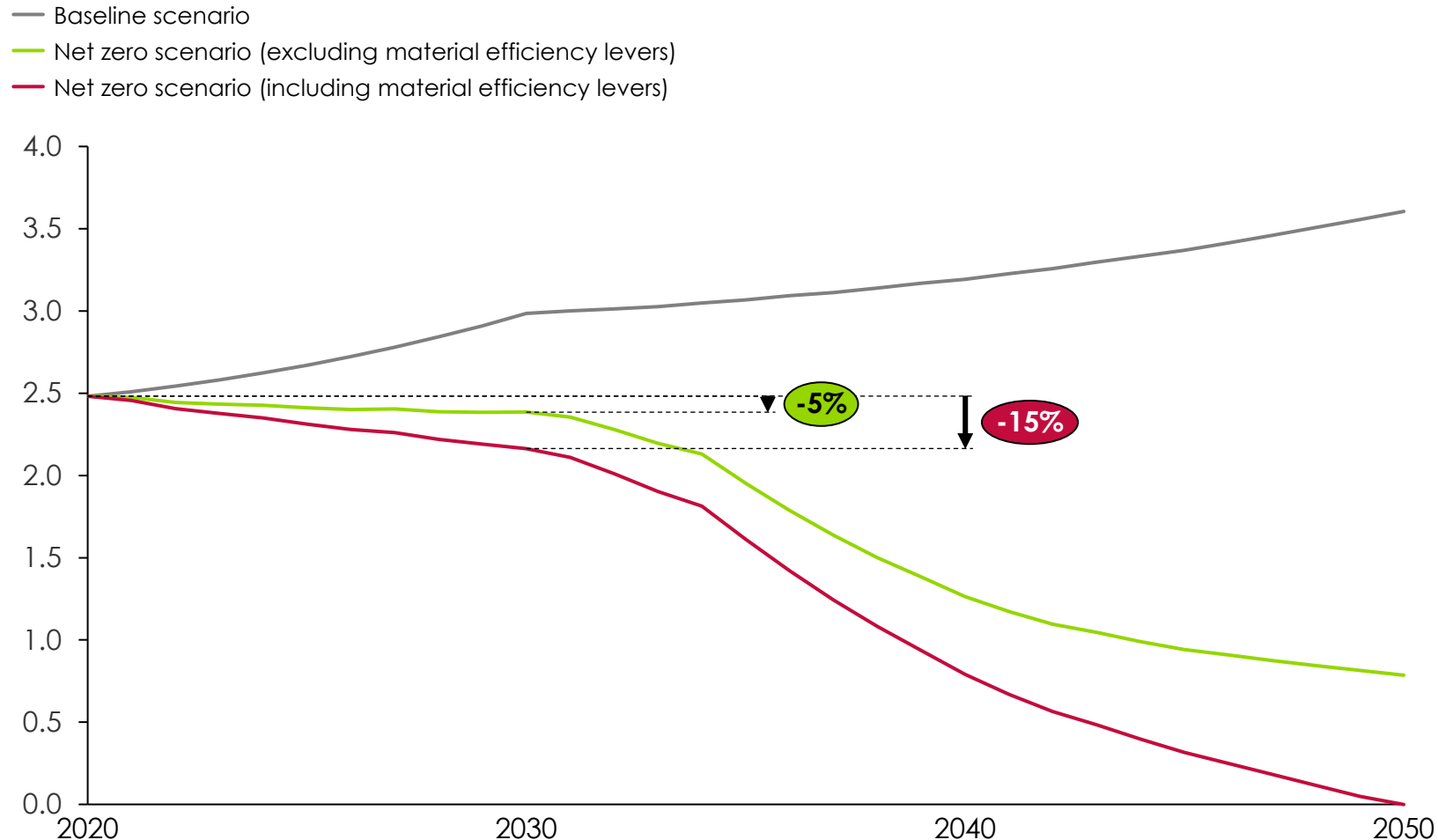

### This section will discuss the:

- **Levers to decarbonise the production of material inputs** (cement, steel, bricks, glass, aluminium)
- **Material efficiency and building design levers** to reduce demand for material inputs

# 2.1 Decarbonising material inputs



# Producing concrete requires temperatures of 1,400°C, which are currently achieved by burning fossil fuels; the chemical process of making cement also generates CO<sub>2</sub>

Pre-read only

## Global thermal energy intensity of clinker production by fuel, 2022 GJ/t clinker; NZE scenario

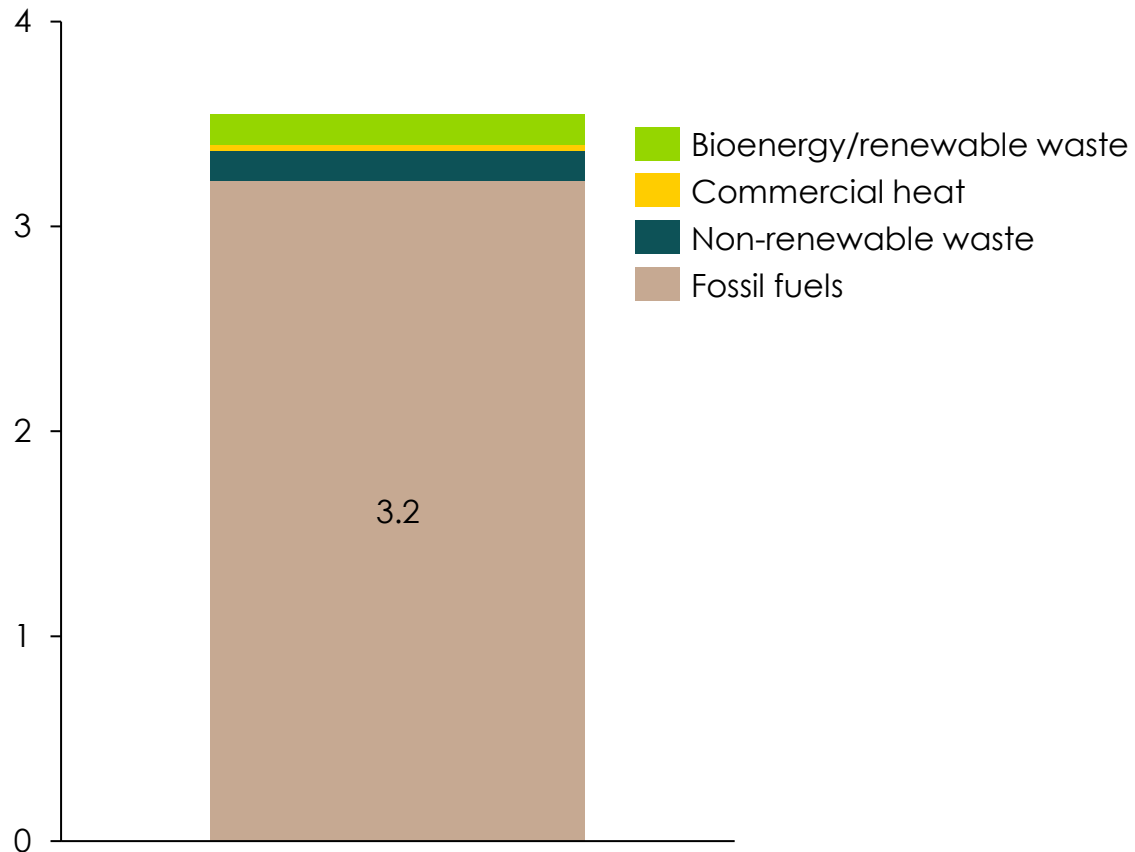

## Process emissions – the chemistry of concrete



- Clinker is a material produced in the manufacture of cement as an intermediary product
- Clinker making involves several **chemical reaction** acting on the various ingredients of **limestone**
- One of them is limestone (CaCO<sub>3</sub>) decomposing to free lime (CaO) and carbon dioxide (CO<sub>2</sub>)



# The majority of emissions in the concrete production cycle come from clinker production

Pre-read only

■ Process emissions ■ Energy emissions

Emissions  
% CO<sub>2</sub>  
Emissions  
of total

Illustration

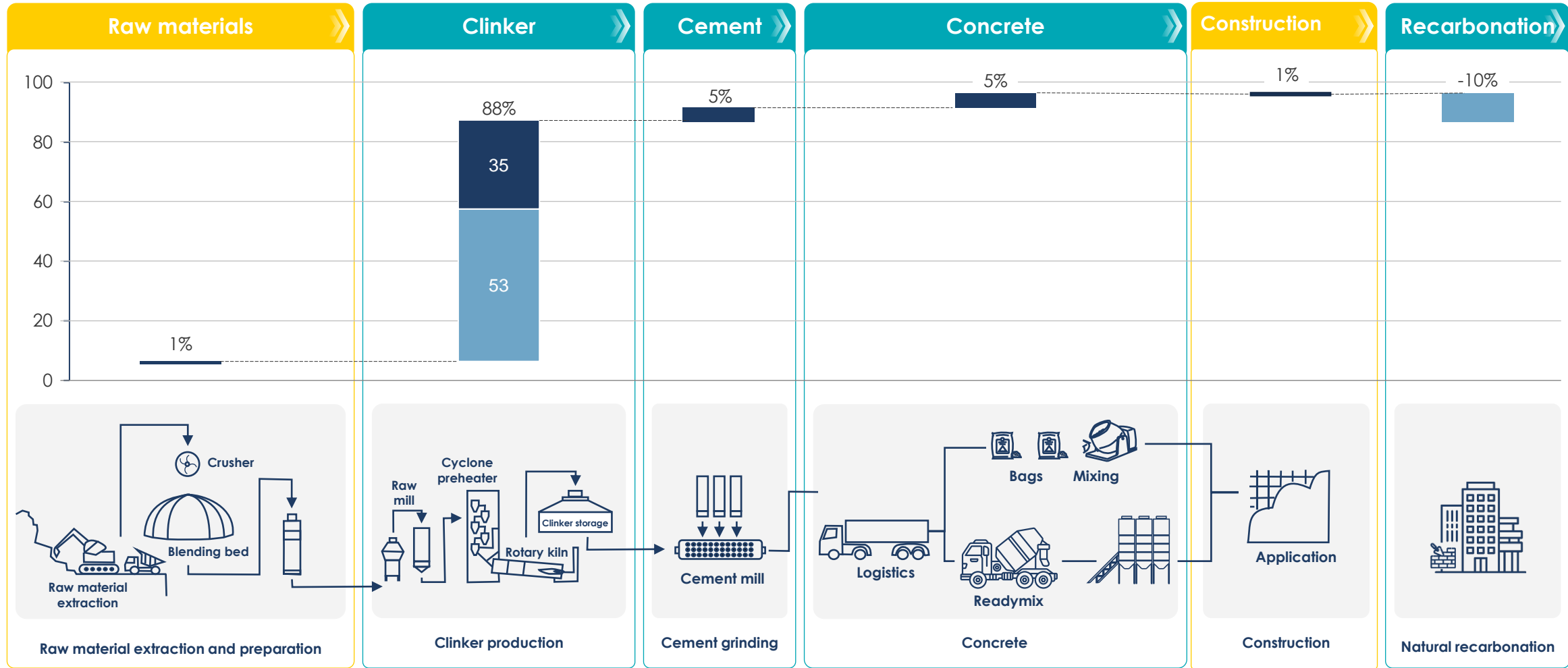

Value chain included in the analysis (scope 1 and 2)

Note: This illustration covers scope 1 and 2 emissions and includes total raw material extraction. Other construction materials are not considered in this analysis.  
 Sources: McKinsey 'Laying the foundation for zero-carbon cement', Decarbonisation Pathways for the Australian Cement and Concrete Sector, Material Economics Industrial Transformation 2050, GCCA 2050 Cement and Concrete Industry Roadmap for Net Zero Concrete

# Decarbonising concrete and cement requires a set of technologies and levers, CCUS being the main one

## Net zero, 1.5 degree aligned concrete and cement sector

GtCO<sub>2</sub> / year

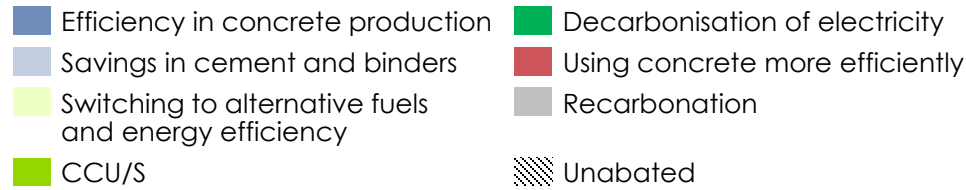

### Reducing process emissions:

- Using less clinker per unit of cement by using less emissions-intensive supplementary cementitious materials (SCMs)
- Using less cement per unit of concrete by increasing strength of cement and industrialising production process
- Bringing alternative low or zero carbon chemistries to market (e.g., alternative binders, decarbonated raw materials)

### Bringing production emissions close to zero:

- Addressing heat emissions through thermal efficiency measures and replacing fossil fuels with waste and biofuels, hydrogen, or electrification
- Capturing remaining process and heat emissions, in order to store or utilise them

**Using concrete more efficiently:** material efficiency and design levers (to be explored in next section 2.2)

**Recarbonation:** concrete reabsorbs CO<sub>2</sub> through its lifecycle

Source: Mission Possible Partnership (2023), *Making Net Zero Concrete and Cement Possible*; Mission Possible Partnership (2022), *Making Net Zero Steel Possible*

# However, CCUS will not scale significantly until the mid-2030s; this is also the case for all industrial sectors

## CO2 capture by sector in Base scenario

Mt CO2e / year

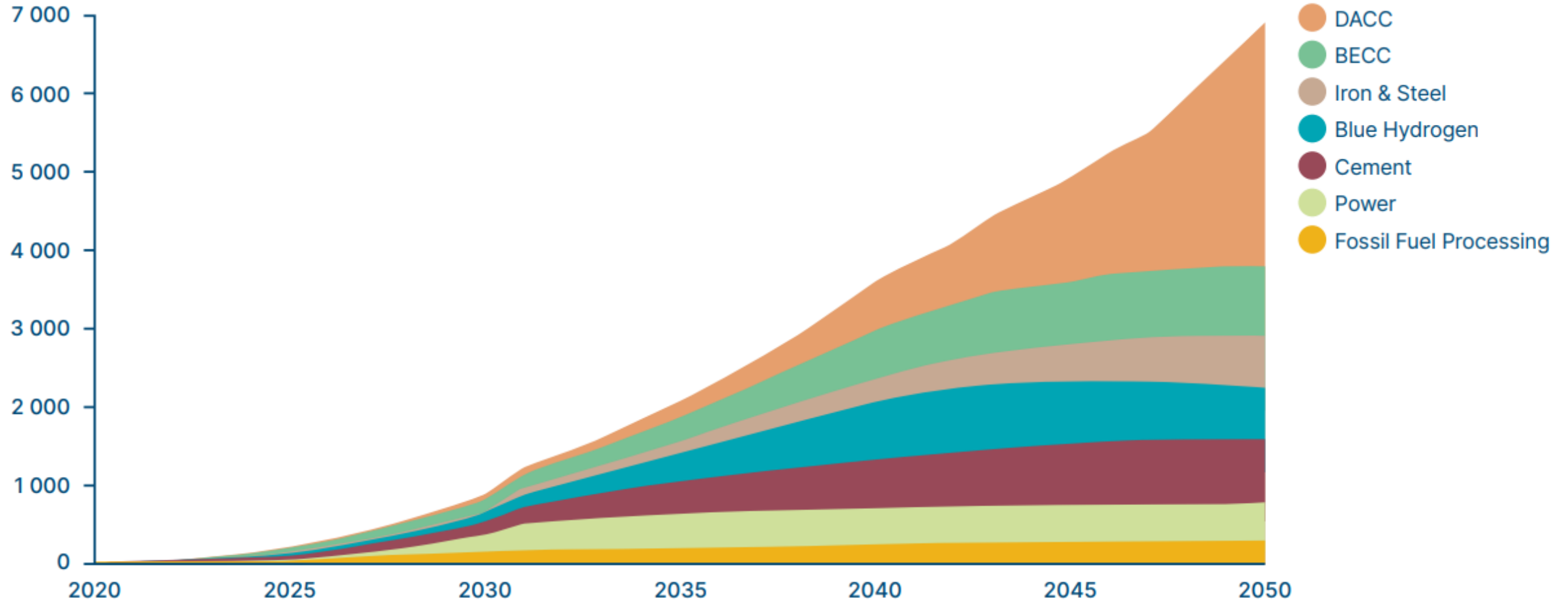

Source: Systemiq analysis for the ETC (2022)

Producing steel requires very high temperatures of 2,000°C, which are currently achieved by burning fossil fuels; the chemical process of making steel also generates CO<sub>2</sub>

Pre-read only

### Energy demand for iron and steel by fuel, 2022

EJ; NZE scenario

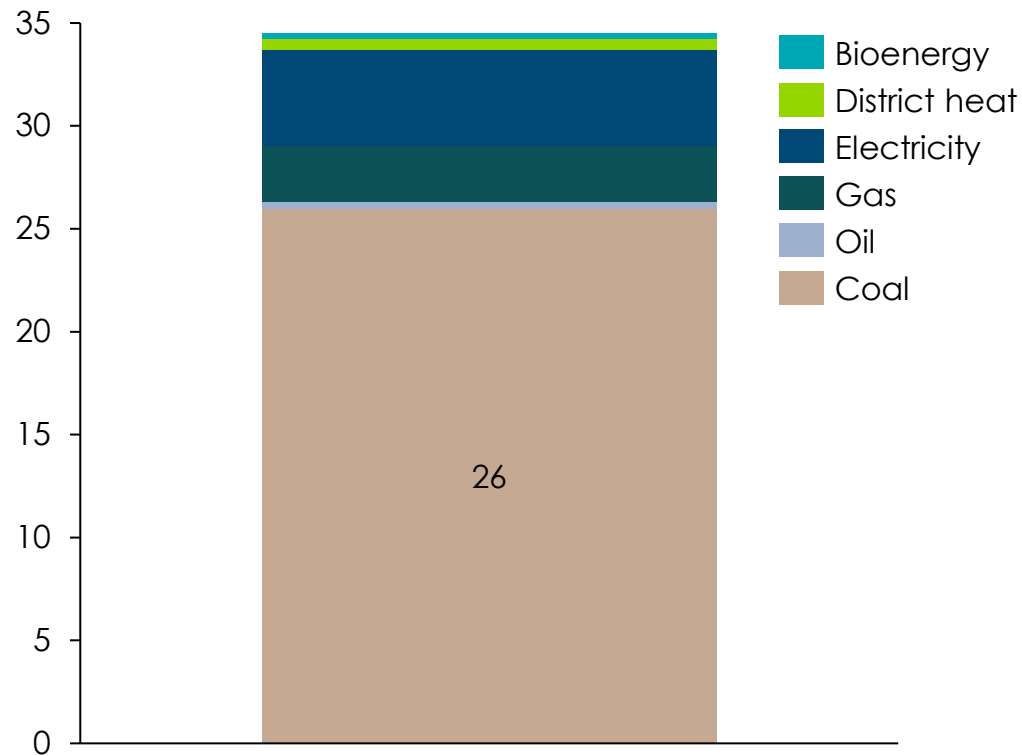

### Process emissions – the chemistry of steel





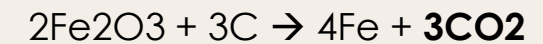



- In the main chemical process used to make primary steel, iron ore (Fe<sub>2</sub>O<sub>3</sub>) and coal react to become iron and carbon dioxide

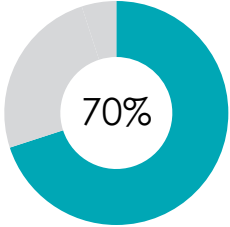

- Steel used in construction is often **a mix of primary and recycled (scrap) steel**, with primary steel ratios higher in e.g. load-bearing beams
- Recycled steel are often used in mature markets such as NA and EU, and increasingly China

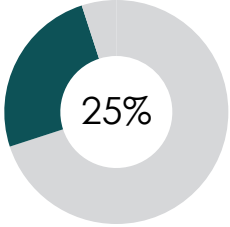
# Nearly all the world's steel is made through one of three main production routes, each has its own emission profiles due to different production fuels

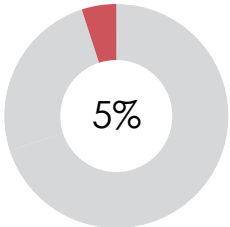
Pre-read only

Production technology	Details	% share of global production in 2020	Average production emission by technology tonnes of CO <sub>2</sub> per tonne of crude steel (t CO <sub>2</sub> /t CS)
<b>Blast furnace–basic oxygen furnace (BF-BOF)</b>	<ul style="list-style-type: none"> <li>Iron ore is reduced in the blast furnace to molten iron, which is subsequently refined to crude steel in the basic oxygen furnace</li> <li>Requires temperatures in the range of 1,100°C to 1,600°C, currently achieved with <b>fossil fuels</b></li> </ul>	 <p>70%</p>	 <p>2.1</p>
<b>Electric arc furnace (EAF)</b>	<ul style="list-style-type: none"> <li>Uses <b>electricity</b> to melt scrap steel</li> <li>Depending on scrap availability and plant configuration, other sources of metallic iron such as direct reduced iron (DRI) or hot metal can also be used</li> </ul>	 <p>25%</p>	 <p>0.5 (average, highly dependent on the carbon intensity of the electricity supply)</p>
<b>Direct reduced iron–electric arc furnace (DRI-EAF)</b>	<ul style="list-style-type: none"> <li>Reducing iron ore <b>without melting it</b></li> <li>Use a <b>reducing gas</b> (typically a blend of hydrogen and carbon monoxide derived from natural gas)</li> </ul>	 <p>5%</p>	 <p>1.2 (when using natural gas)</p>

Source: Mission Possible Partnership (2022), *Making Net Zero Steel Possible*

# Key emissions reduction levers to achieve net zero in the steel industry are scrap use, iron reduction and CCU/S

## Cumulative GHG emissions between 2022 and 2050

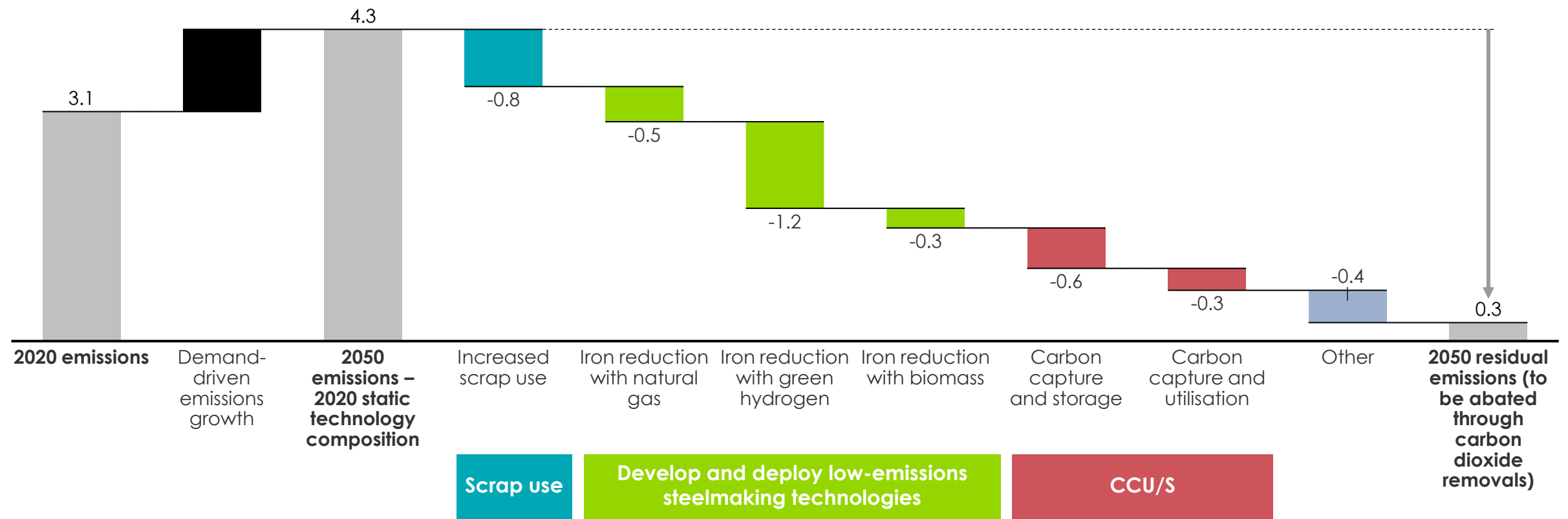
Gt CO<sub>2</sub>

Note: The “2050 emissions – 2020 static technology composition” bars in both panels represent what annual emissions would be in 2050 if projected steel demand were met by the same technologies in the same proportions as in 2020. This is not the same as the Baseline scenario, in which some production technology changes occur even in the absence of concerted efforts to decarbonise the steel industry.

Source: Mission Possible Partnership (2022), *Making Net Zero Steel Possible*

# Cement, concrete and steel account for 95% of embodied emissions, but other materials also require attention

## Cement and steel contribution to global construction material carbon impact

%

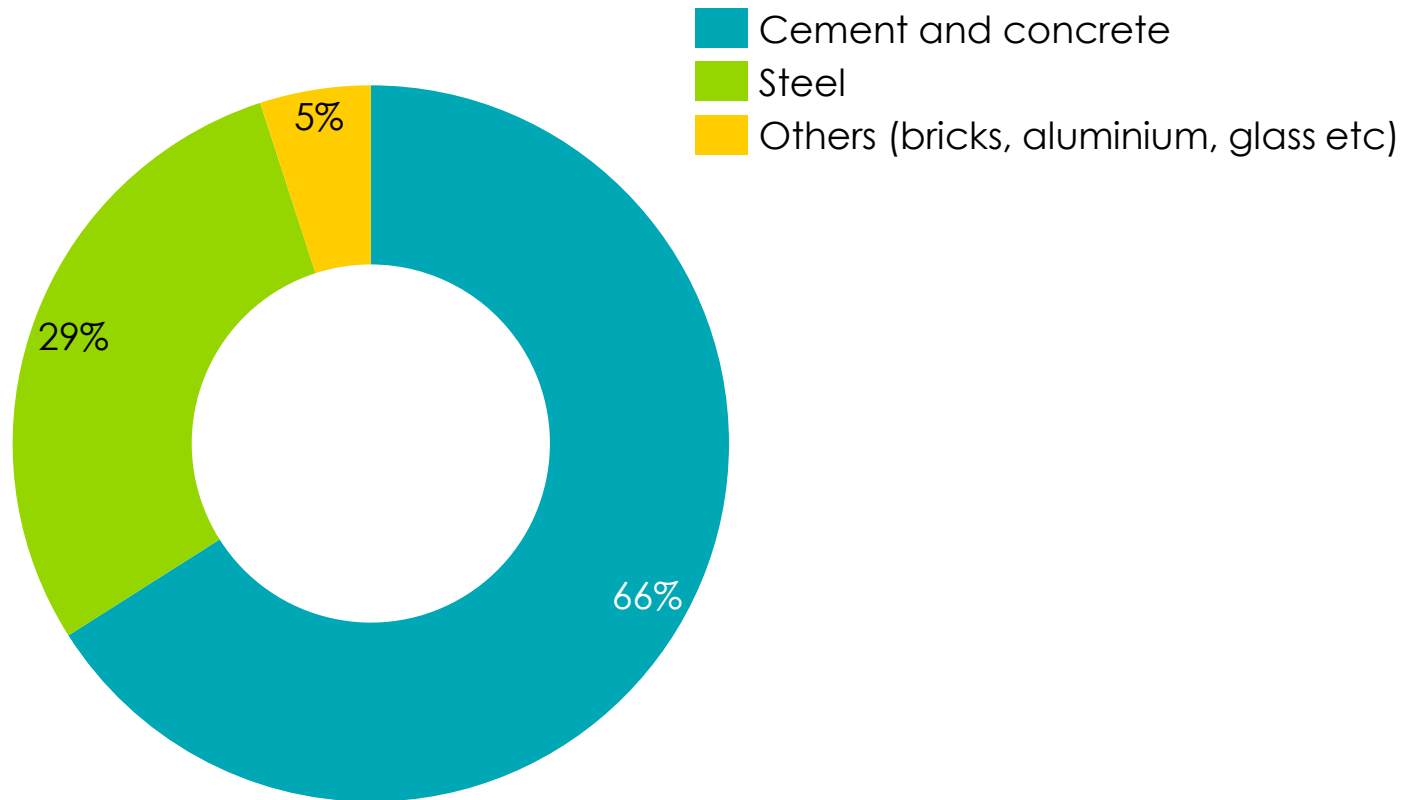

**This section will cover, at a lighter touch:**

- Aluminium
- Glass



# For aluminium, clean electrification is the biggest lever; this means ~70% of emissions can be mitigated by 2035; however, material efficiency levers still play an important role to 2050

## Emission reduction pathways

Gt CO2e / year

Remaining emissions

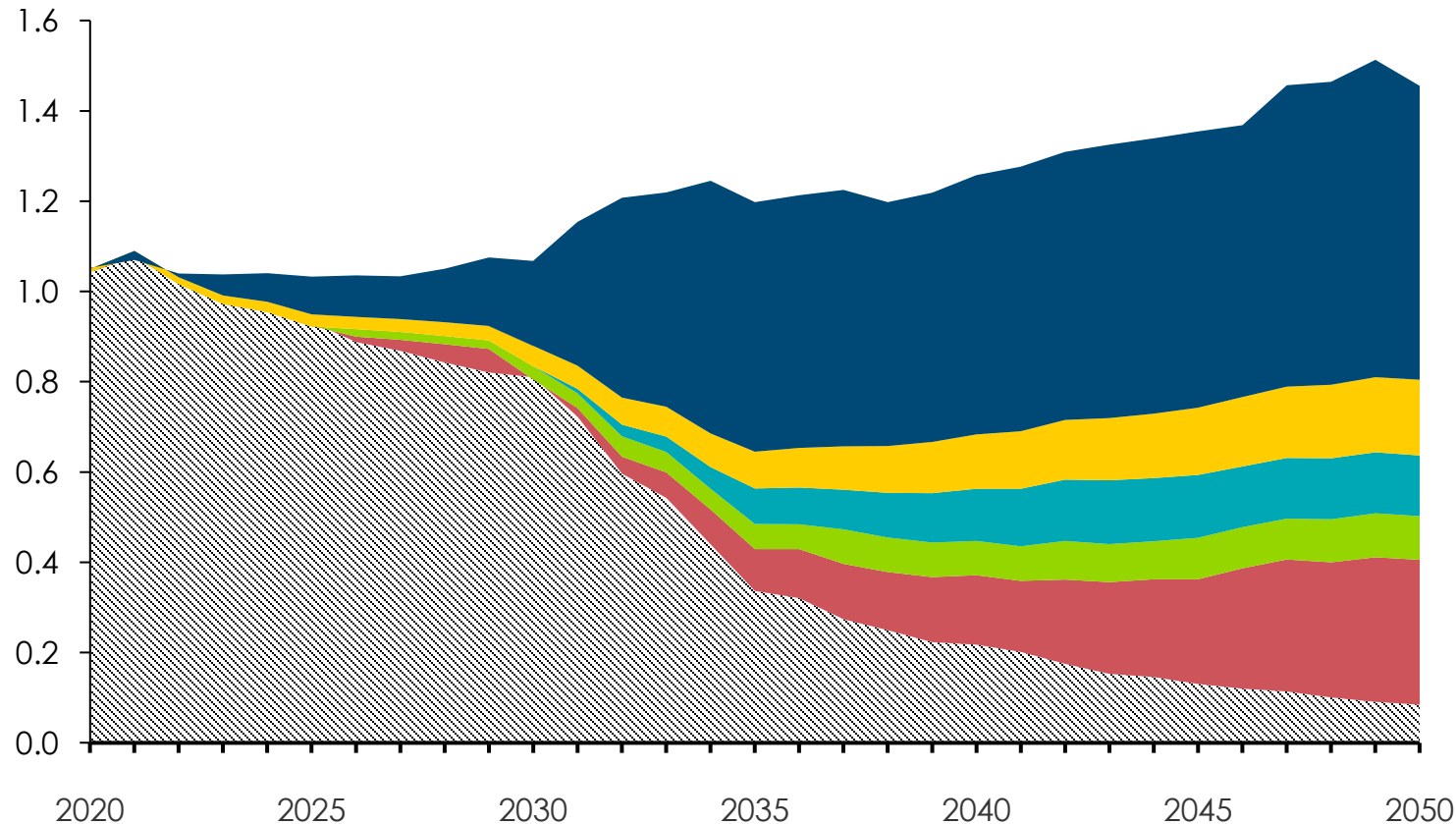

Cumulative reduction to 2050

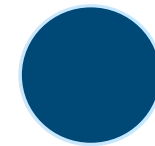

Low-carbon power

55%-60%



Additional fuel switching

10-15%



Low-carbon anode production technologies (e.g., CCS retrofits)

10%



Low-carbon refineries (e.g., electric and hydrogen boilers)

5%-10%



**Material and resource efficiency**

- Improved recycling rates
- Design efficiency

15%-20%

*To be discussed in next section*



Source: Mission Possible Partnership (2022), *Making Net Zero Aluminium Possible*

## Similarly, clean electrification will account for ~90% of emissions reductions in glass production; this is also important for bricks

### Emission intensity of glass between 2018 and 2050, UK

† CO<sub>2</sub> / t

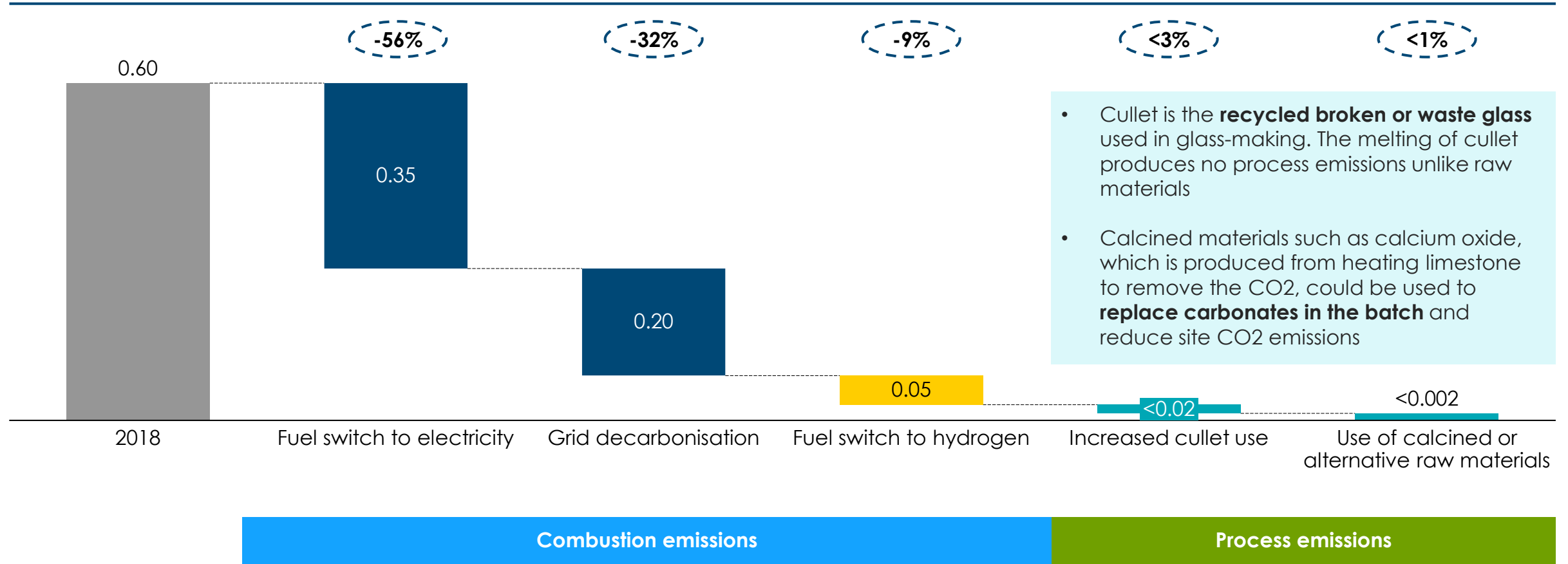

Source: British Glass, *Glass sector Net zero strategy 2050*

# Decarbonising material inputs could reduce cumulative embodied carbon of new buildings to 2050 by ~50%, but will still produce ~40 GtCO<sub>2</sub>

Potential reduction of baseline embodied carbon from decarbonising material inputs, cumulative emissions 2023-50  
Gt CO<sub>2</sub>e

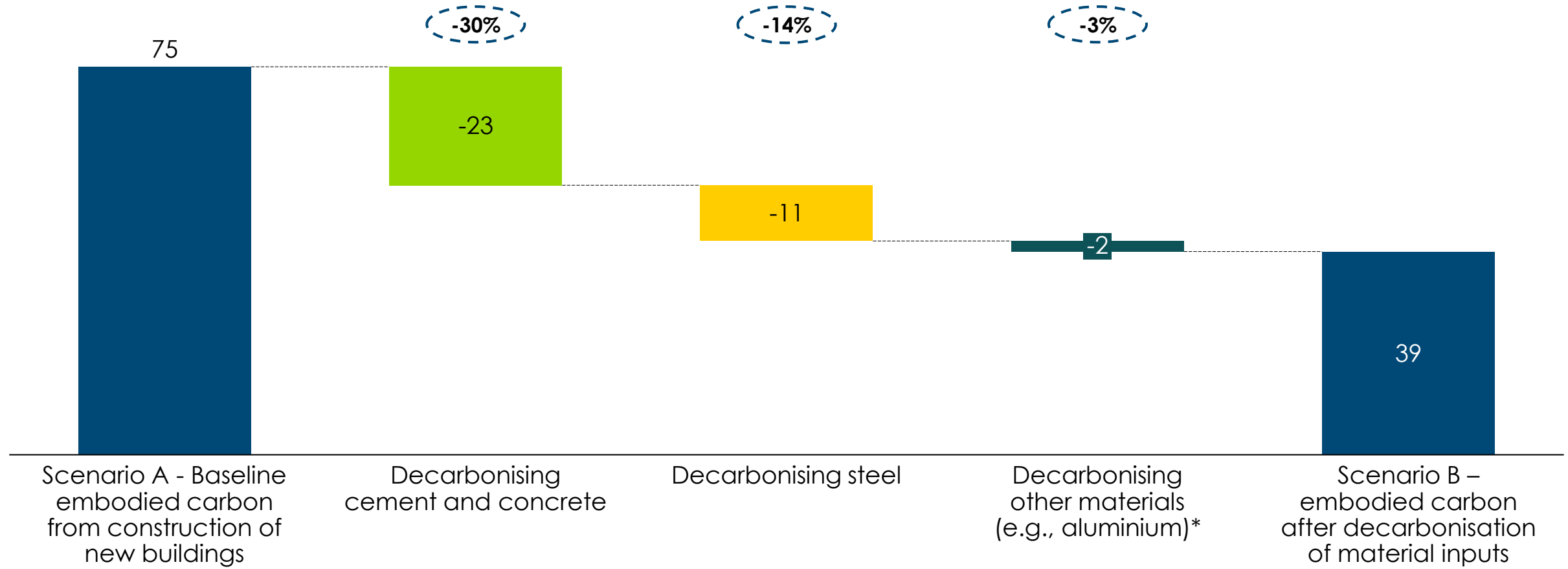

Note: \*Assuming other materials will decarbonise at the rate of how aluminium decarbonise given it's largely focused on power decarbonisation  
Sources: Systemiq analysis for ETC (2024)

## 2.2 Material efficiency and substitution levers



# There are other strategies to reduce embodied carbon; their impact and feasibility varies across the project lifetime

## Impact of decision-making on embodied carbon reduction strategies

Embodied carbon reduction potential, %

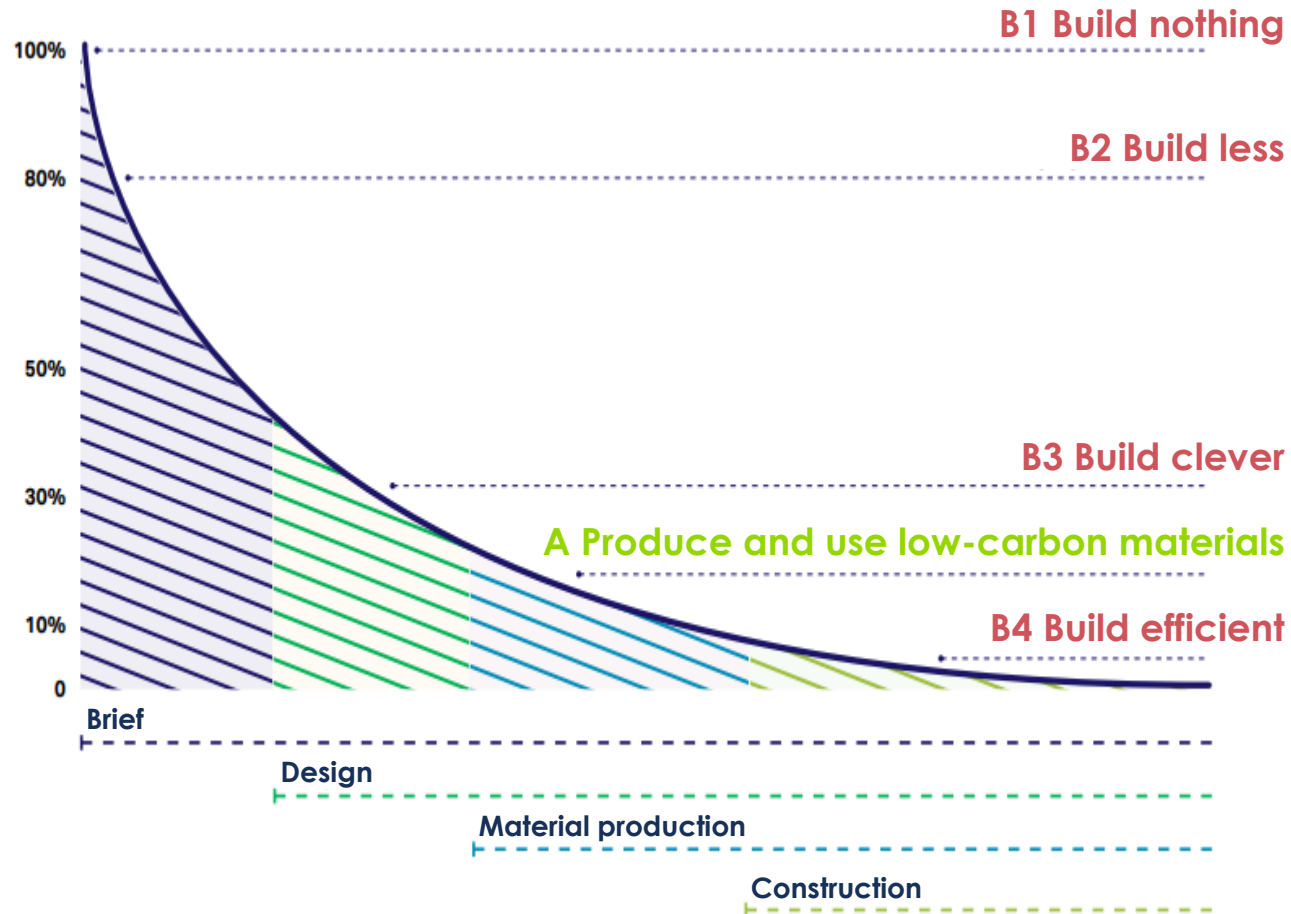

### Build nothing

- Re-use or extend use of existing buildings

### Build less

- Optimise building use and service efficiency
- Better urban planning

High impact – but much harder to implement

### Build clever

- Building geometry
- Innovative construction solutions
- Material substitution

### Build efficient

- Efficient construction methods
- Circularity approach

Relatively lower impact – but easier to implement

Source: WBCSD & Arup (2023), *Net-zero buildings Halving construction emissions today*

# Focusing on build clever and build efficient first, there are a huge variety of strategies that developers can adopt to reduce upfront embodied carbon across all building layers

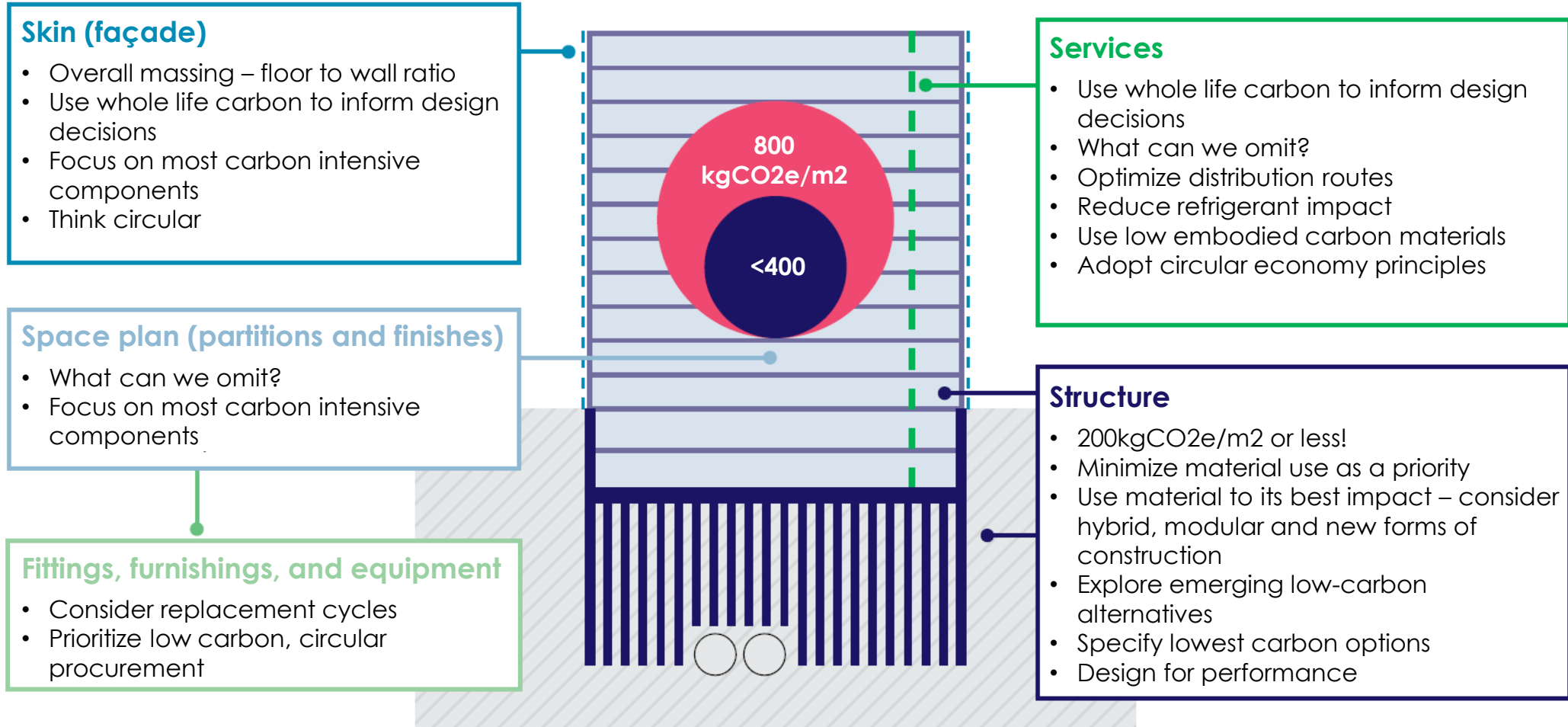

## There are three main levers to build clever



### Building design choices

Optimize the building's shape, height, and layout to use fewer materials without compromising functionality

- Area efficiency
- Wall to floor ratio
- Window-to-wall ratio
- Building height



**15-30% reduction  
in cement & concrete demand to 2050**

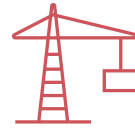

### Innovative construction solutions

Focus on lightweighting and material intensity without compromising on safety and durability

- Minimize material use through innovative structures and techniques



**15% reduction  
in steel demand to 2050**



### Material substitution

Replace conventional concrete and cement with sustainable alternatives to significantly lower carbon emissions

- Rammed earth
- Timber



# Design and aesthetic choices in the design stage can massively reduce embodied carbon

## Area efficiency

### High-rise vs low-rise – floor efficiency

Net-to-gross ratio, %

■ Core ■ Occupied area

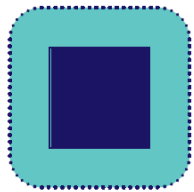

108 floor levels  
above ground  
Net/gross 69%

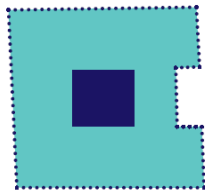

9 floor levels  
above ground  
Net/gross 80%



8 floor levels  
above ground  
Net/gross 87%

Higher efficiency, lower embodied carbon

Net-to-gross ratio is **the overall efficiency factor of net usable area to gross construction area**

- Varies by more than **20%** in different versions of the same building typology
- At the lower efficiency, companies are **constructing more overall building to deliver the same functionality**

## Building height

### London mid/high-rise buildings benchmarking

Upfront embodied carbon intensity, kgCO<sub>2</sub>e/m<sup>2</sup> GIA

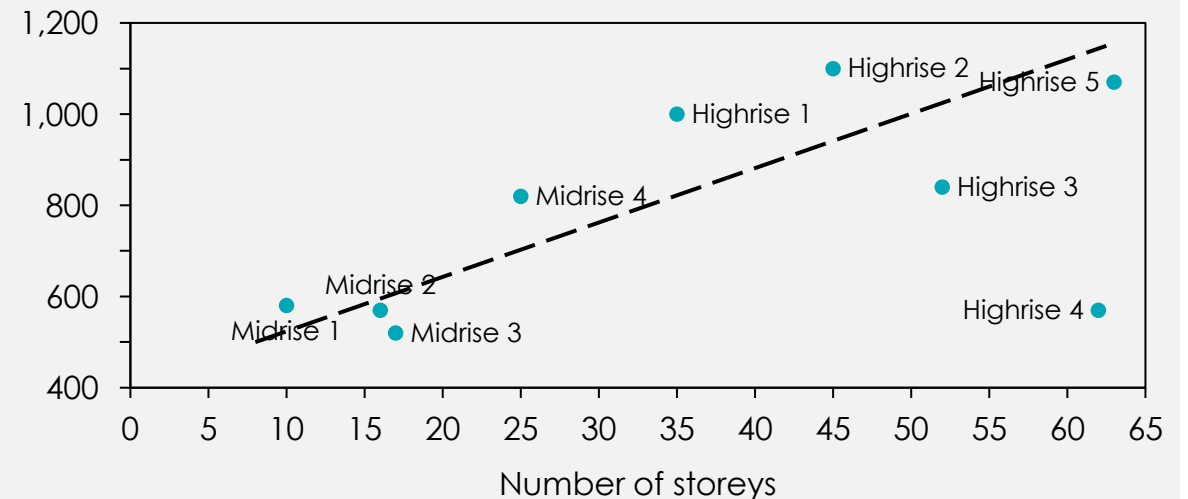

**Taller buildings typically require more structure** (thicker core walls, bigger columns, larger foundations, etc.) **and more space and equipment** associated with vertical movement of people (lifts and stairs) **and building services** (risers, interstitial plant provision, etc.)

Embodied carbon per m<sup>2</sup> can be **50% higher** to provide the same net useable area between high-rise and low-rise construction

# Taller buildings have a higher embodied carbon intensity per m<sup>2</sup>, requiring significantly more material as structural support

## Wall to floor ratio

### Wall-to-floor (W2F) ratio comparison

W2F

Wall Floor



W2F = 0.50 (poor)



W2F = 0.35 (good)

Lower W2F, lower embodied carbon

- W2F ratio can typically vary from about **0.3 to 0.5**
- At its upper end, it can represent **more than 60% of additional façade area**, driving additional embodied carbon into the design

## Column grids and floor-to-floor heights

### Weight-to-depth relationships for a comparable composite floor plate design kgCO<sub>2</sub>e/m<sup>2</sup>

Minimum depth solution  
9m x 9m grid

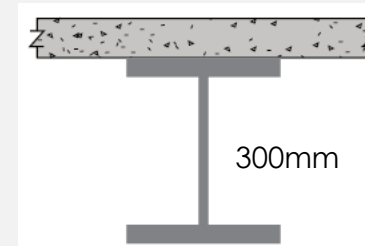

100 kgCO<sub>2</sub>e/m<sup>2</sup>

Minimum weight solution  
9m x 9m grid

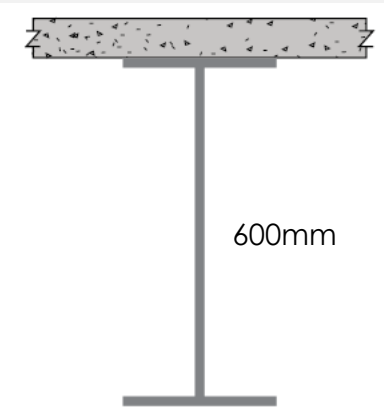

50 kgCO<sub>2</sub>e/m<sup>2</sup>

**The span of the building floor plate** between columns and walls and the allowable depth the structure can occupy (span-to-depth ratio) can significantly impact the overall amount of material needed, which in turn is directly linked to the overall carbon footprint

# Navigating trade-offs between embodied carbon and operational energy use can be challenging; passive heating and cooling techniques should be prioritised

Just focusing on embodied carbon could lead to sub-optimal choices regarding operational energy (e.g., single glazing over triple)

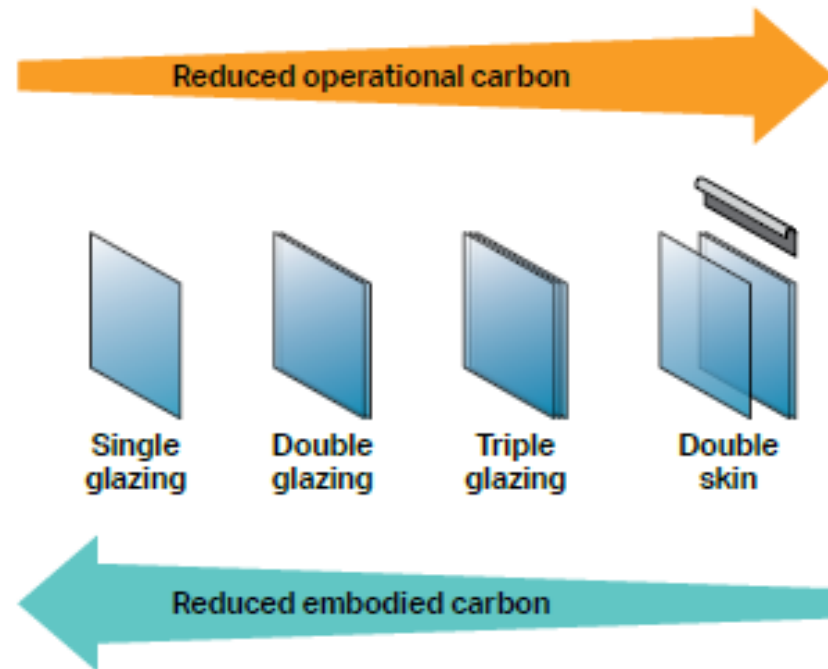

Developers should consider the trade-offs between design choices

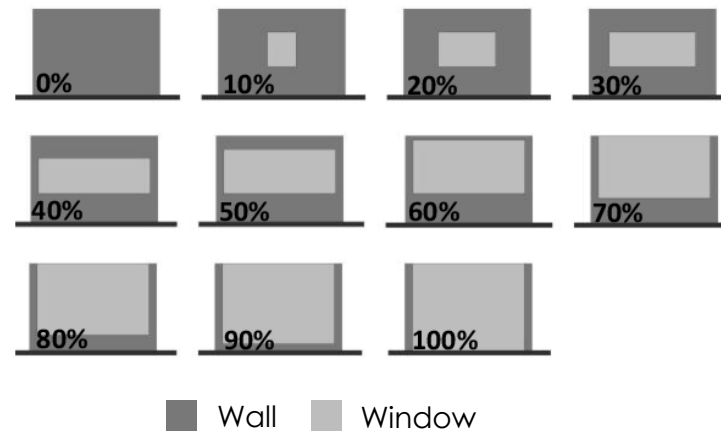

For example, the window-to-wall ratio can lead to ~ 80% variation in embodied carbon

The WWR also has implications for a building's **operational emissions**:

- Natural light vs artificial light needs
- Solar gain vs heating / cooling needs

There are a number of passive heating and cooling techniques which have no / minimal impact on embodied carbon

- Orientation
- Airtight construction
- Insulation – as a share of total embodied carbon, many insulating materials (e.g., natural fibres) have a very small impact on embodied carbon



# Before net-zero concrete is available, using lower carbon intensity structural components can reduce the carbon impact of reinforced concrete in buildings



The **floorplate system** refers to the horizontal elements that make up the floors of the building. It's a critical part of the building's structure as it supports the weight of people, furniture, and equipment. A floorplate typically consists of:

- **Slabs:** These are the **large, flat surfaces** (like the floors you walk on). They are usually made of **reinforced concrete**
- **Beams:** These are horizontal structural **elements that support the slabs**. They can be made of steel and concrete

## Comparison of common concrete floorplate systems

Embodied carbon, kgCO<sub>2</sub>e/m<sup>2</sup>

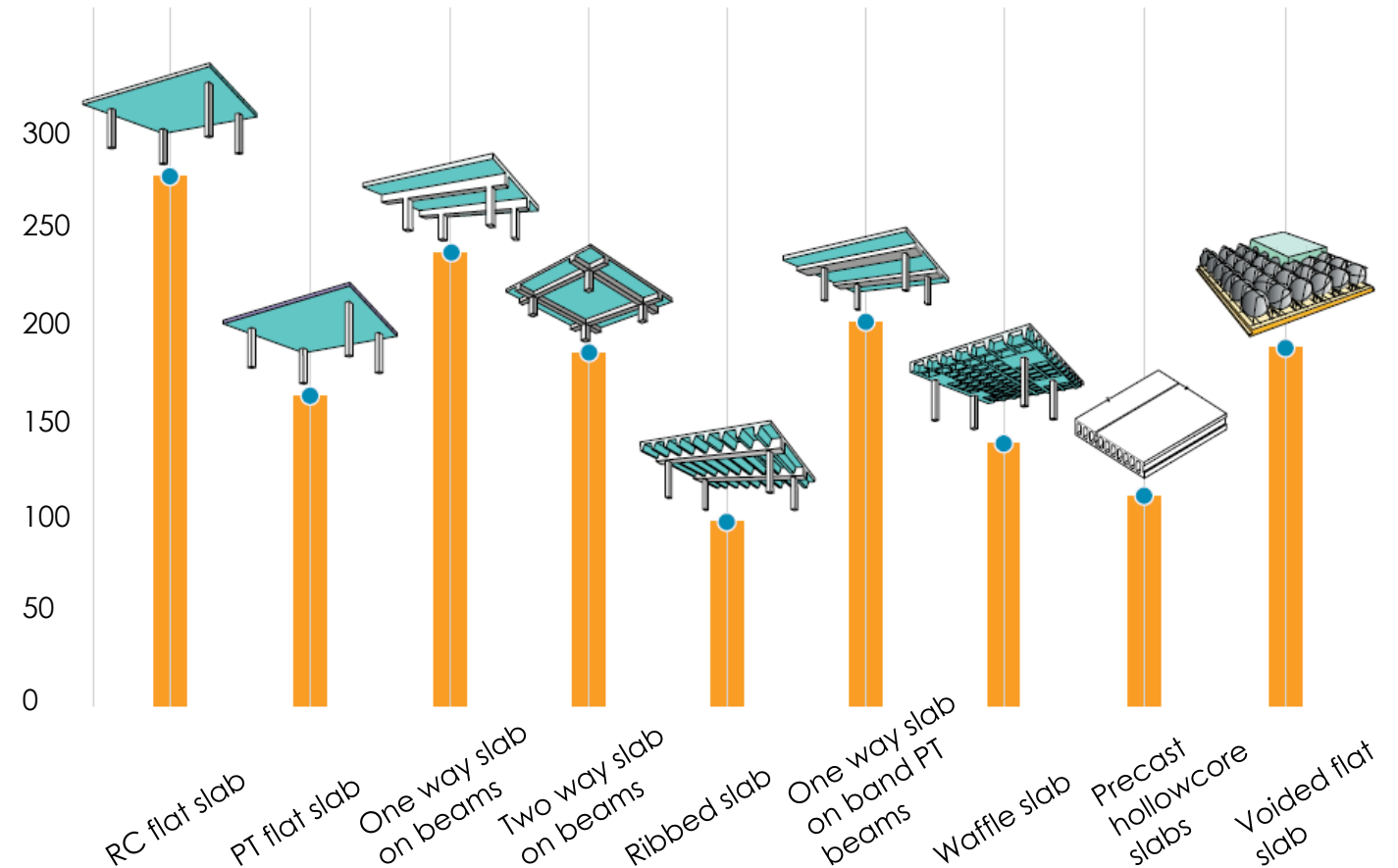

# Similarly, optimizing steel structural frames can lead to less steel use and subsequently emit less carbon

## Example of innovative solution to reduce steel intensity: tree column floor system

Developed by Make Architects and Arup

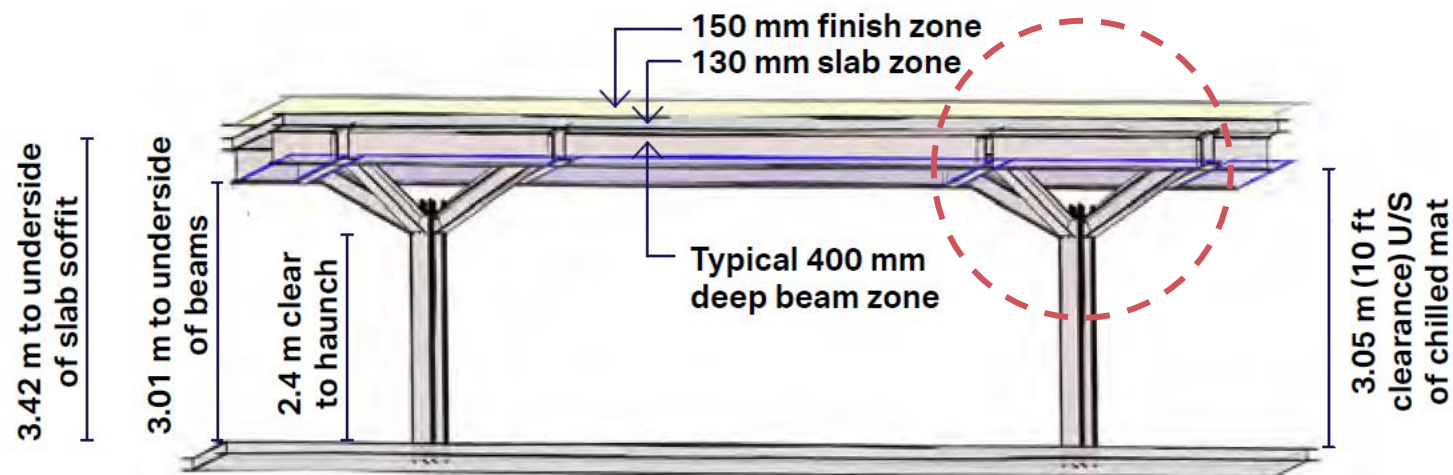

The column heads effectively **shorten the spans** of the main beams and **reduce both depth and weight**, comparing to conventional steel composite floor plate



The carbon savings estimated from this simple modification to convention is in **the region of 15-20%** when compared to a standard floorplate system

# Lower embodied carbon design and construction choices face a number of barriers and trade-offs

## Financial and legal barriers

- **Project cost, timescales, functionality, and aesthetics** are prioritised over sustainability
- **Contract structures** enforce hierarchies and limit information sharing
- **Litigious industry environment** makes pursuing novel products difficult
- **Concerns over durability** and associated liability and reputational risk
- **Policy and regulatory limitations** to use of novel materials

## Institutional barriers

- **Fragmented supply chain** and ineffective integration of different actors early in the planning process
- Current standards may **prevent use** of certain types of cement and other construction materials for **safety reasons**
- **Conservative nature** of clients and practitioners

## Knowledge and perception barriers

- **Perceived unreliability and risk** specifically about durability
- **Lack of information** on performance of novel materials
- Lack of consistent and comparable **methods** for calculating and reporting embodied carbon
- **Negative perceptions** of low-carbon materials
- Perception of **high cost**

## Concrete floorplate systems illustration

Embodied carbon, kgCO<sub>2</sub>e/m<sup>2</sup>

Reinforced concrete flat slabs



Typically **180 kg CO<sub>2</sub>e/m<sup>2</sup>**  
for a 9x9 m grid with comparable loading





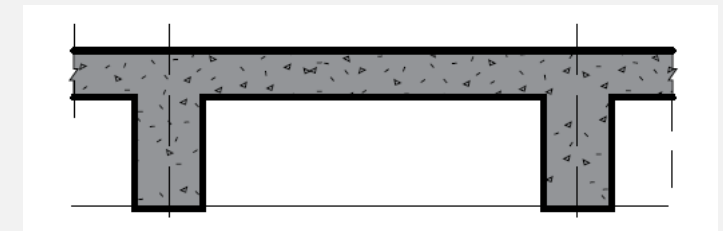

↓ **30%+ reduction**

Reinforced concrete waffle slabs









Typically **120 kg CO<sub>2</sub>e/m<sup>2</sup>**  
for a 9x9 m grid with comparable loading

# There are also some encouraging signs that more innovative new low-carbon intensity materials may emerge in the not-too-distance future (1/2)

Alternative materials	Applicable building layers	Embodied carbon	Details and carbon impact		Barriers	
<b>Hempcrete</b>	Skin (façade); internal wall	Carbon negative (Sequester over 100 kgCO <sub>2</sub> /m <sup>2</sup> )			<ul style="list-style-type: none"> <li>A mix of hemp fibers, lime, and water</li> <li><b>More atmospheric carbon is locked away in the material</b> for the lifetime of the building than was used in its production and use</li> </ul>	<ul style="list-style-type: none"> <li>Not suitable for structural use</li> <li>Limited awareness</li> <li>Limited building codes compliance</li> </ul>
<b>Rammed earth</b>	Structure; internal wall	50-100 kg CO <sub>2</sub> e/m <sup>3</sup>			<ul style="list-style-type: none"> <li>Compressed natural soil, sometimes stabilized with cement</li> <li>Requires <b>significantly less energy</b> and produces minimal waste during construction comparing to concrete</li> <li><b>Excellent thermal mass</b> property to reduce operational emissions</li> </ul>	<ul style="list-style-type: none"> <li>Labor-intensive (requires skilled labour)</li> <li>Potential for cracking</li> </ul>
<b>Timber (deep dive next)</b>	Structure; skin (façade)	100-200 kg CO <sub>2</sub> e/m <sup>3</sup>			<ul style="list-style-type: none"> <li><b>Lower overall GHG emissions</b> than traditional concrete and steel, in particular in regions with ample sustainable forestry</li> <li>Potential to sequestration</li> </ul>	<ul style="list-style-type: none"> <li>Supply constrained</li> <li>Susceptible to fire, rot, and pests</li> <li>Needs sustainable forestry practices</li> </ul>
<b>Bamboo</b>	Structure; skin (façade)	50-100 kg CO <sub>2</sub> e/m <sup>3</sup>			<ul style="list-style-type: none"> <li><b>Very low carbon footprint</b></li> </ul>	<ul style="list-style-type: none"> <li>Limited building codes compliance</li> <li>Potential for insect infestation</li> <li>Low performance for operational emissions</li> </ul>

For reference, embodied carbon of **reinforced concrete** is **240-300** kg CO<sub>2</sub>e/m<sup>3</sup>, and **steel** is **12,000-16,000** kg CO<sub>2</sub>e/m<sup>3</sup>, depending on production process

## There are also some encouraging signs that more innovative new low-carbon intensity materials may emerge in the not-too-distance future (2/2)

Alternative materials	Applicable building layers	Embodied carbon	Embodied carbon impact	Barriers
<b>Low-carbon bricks and blocks</b>	Skin (façade); internal wall	150-250 kg CO <sub>2</sub> e/m <sup>3</sup>	 <b>Recycled bricks</b> made from up-cycled construction waste and a lower temperature firing process	<ul style="list-style-type: none"> <li>Material quality</li> <li>Limited building codes compliance</li> </ul>
		30-150 kg CO <sub>2</sub> e/m <sup>3</sup>	 <b>Earth bricks and blocks (i.e., adobe bricks)</b> , made from compressed earth, sometimes stabilized with small amounts of cement or lime, has low embodied carbon especially if locally sourced	<ul style="list-style-type: none"> <li>Labour-intensive</li> <li>Require stabilization to improve durability</li> </ul>
		20-50 kg CO <sub>2</sub> e/m <sup>3</sup>	 <b>Rice husk ash bricks</b> are bricks made from an agricultural waste product	<ul style="list-style-type: none"> <li>Limited availability</li> <li>Material quality</li> <li>Limited building codes compliance</li> </ul>
		100-200 kg CO <sub>2</sub> e/m <sup>3</sup>	 <b>Mycelium building blocks</b> , Made from fungal mycelium grown in agricultural waste, are low carbon and biodegradable	<ul style="list-style-type: none"> <li>Limited availability</li> <li>Limited structural use</li> <li>Limited awareness</li> </ul>
<b>Biocement</b>	skin (façade)	100-200 kg CO <sub>2</sub> e/m <sup>3</sup>	 Bio-based cement tiles made from approx. 85% aggregate combined with 15% biocement, with lower embodied carbon	<ul style="list-style-type: none"> <li>Limited structural use</li> <li>Limited awareness</li> </ul>
<b>Straw bale modules</b>	Internal wall	20-50 kg CO <sub>2</sub> e/m <sup>3</sup>	 Compressed straw used for insulation and walls	<ul style="list-style-type: none"> <li>Bulky</li> <li>Requires proper sealing</li> </ul>

**While encouraging, companies cannot only rely on the emergence of new materials that can be deployed at a global built environment scale over the coming decade. A robust net-zero transition plan must have a combination of all sets of levers**

# Used in the right way, modern engineered timber can contribute significantly to lowering the embodied carbon footprint of a building structure

## Comparison of good and bad timber use

Cumulative embodied carbon kgCO<sub>2</sub>e/m<sup>2</sup>

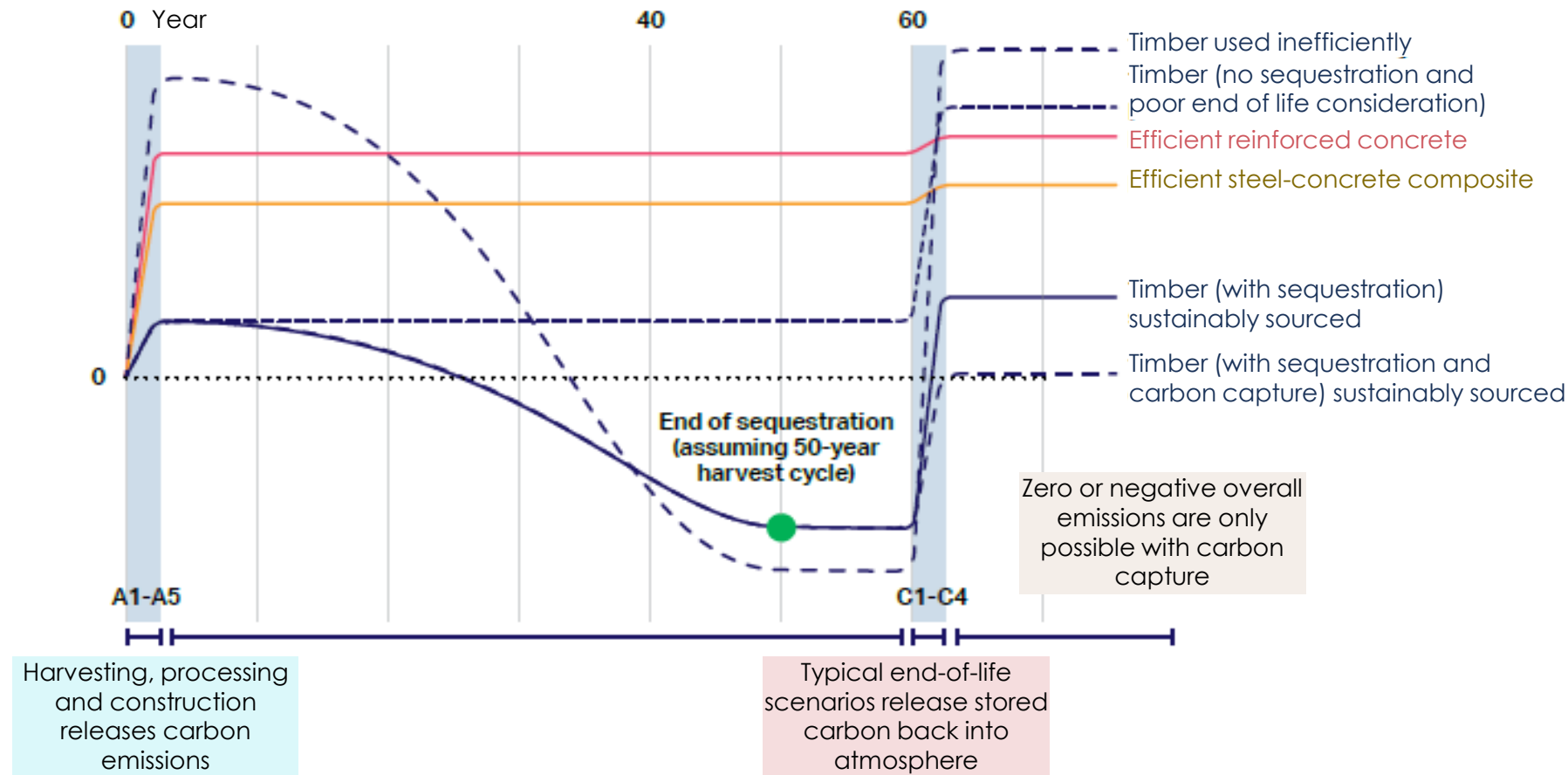

- **Timber has lower overall GHG emissions than traditional concrete and steel**
- Especially in regions with ample sustainable forestry
- **But exactly how high is heavily contested**
- It is very unclear where the boundary lies between **desirable and undesirable timber substitution**

## The timber debate is complex – while it also has indirect embodied carbon benefits, guaranteeing sustainable supply is very challenging

### Uncontested benefits to timber

- **Prefabrication** is easier for timber – lower waste and higher material efficiency
- Timber **aesthetics** mean that less additional material is needed (e.g., plaster, paint, drywall)
- Mass timber has high **insulating** capabilities, requiring less insulation material
- Construction **cost savings** of 15% have been reported

### Contested points or risks to timber

- Challenging to correctly account for carbon, e.g., **incorrect accounting** from the share of tree that cannot be used for timber (e.g., branches) which is burned / left to rot
- **Time dimension**: replanted tree will take decades to re-sequester the emitted carbon
- Cutting trees down before end of life significantly cuts a tree's sequestration potential

*See next slide*

Also important to note that timber is only a viable substitute in certain applications – e.g., low- and mid-rise buildings



# Guaranteeing sustainable supply is the key challenge – one part of this involves cutting trees down at the optimal time in their lifetime

**a** Cutting trees before EOL halves a tree's sequestration potential  
kg of CO<sub>2</sub> sequestered

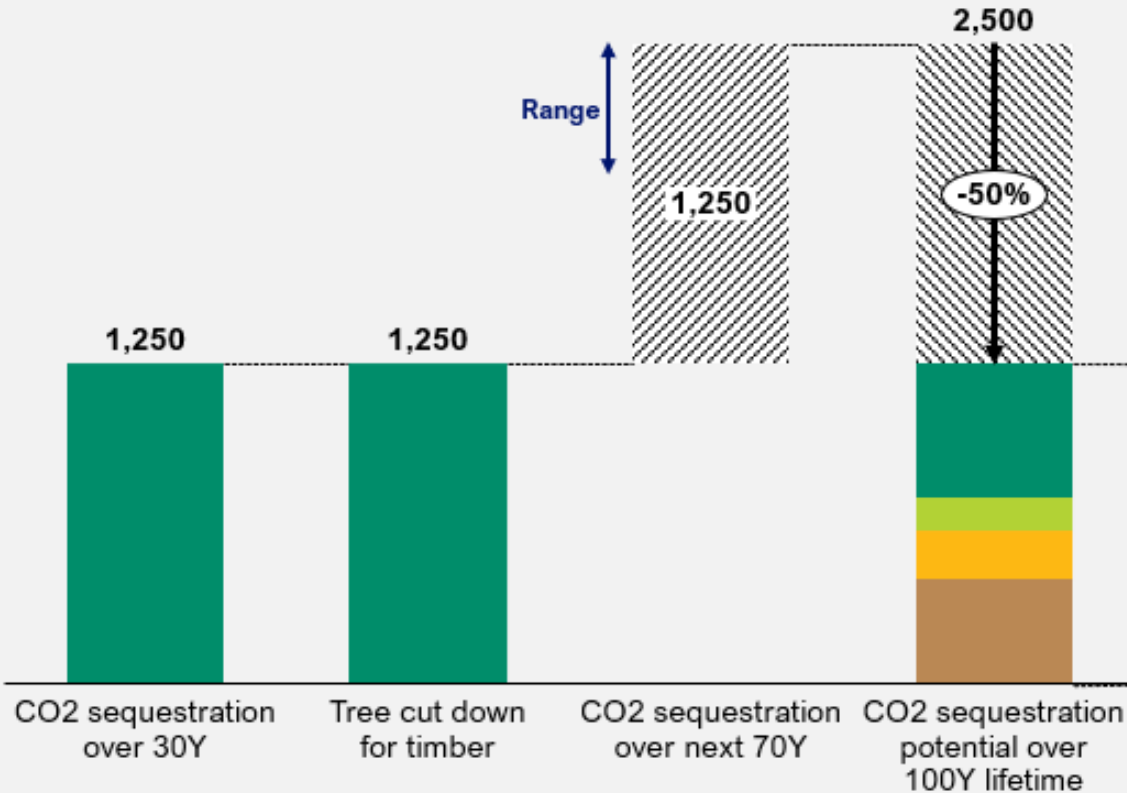

**b** ... with ~50% of the captured carbon being emitted instead of stored  
% of carbon

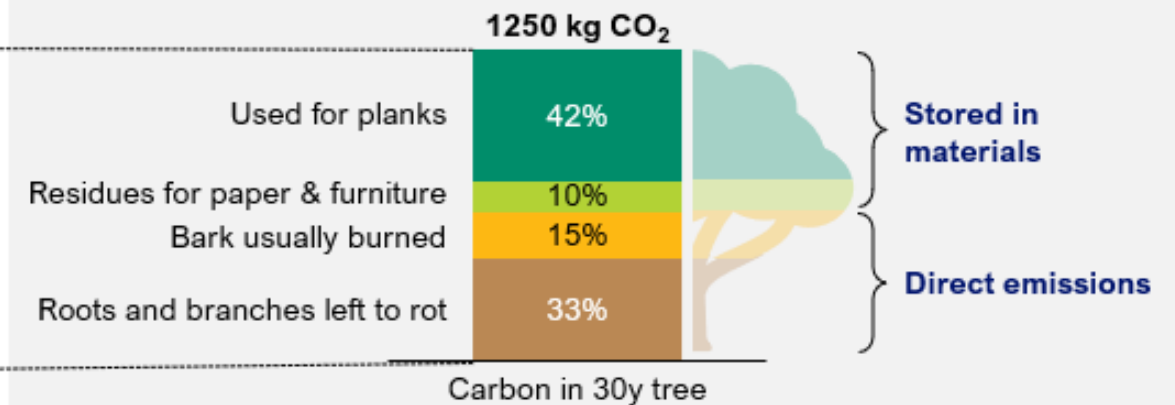

Source: WRI (2023) adapted from Churkina et al 2020; assuming tree sequesters 50% in first 30 years

# Supply of sustainable timber is very limited due to competing demands for land, long lead times and growing demand for sustainable biomass across sectors

## Maximum potential

Maximum achievable only under extremely ambitious systems change scenarios; additional potential NOT to be relied upon.

Global sustainable biomass<sup>1</sup> supply (2050) – illustrative scenario  
EJ/year (primary energy)

Illustrative

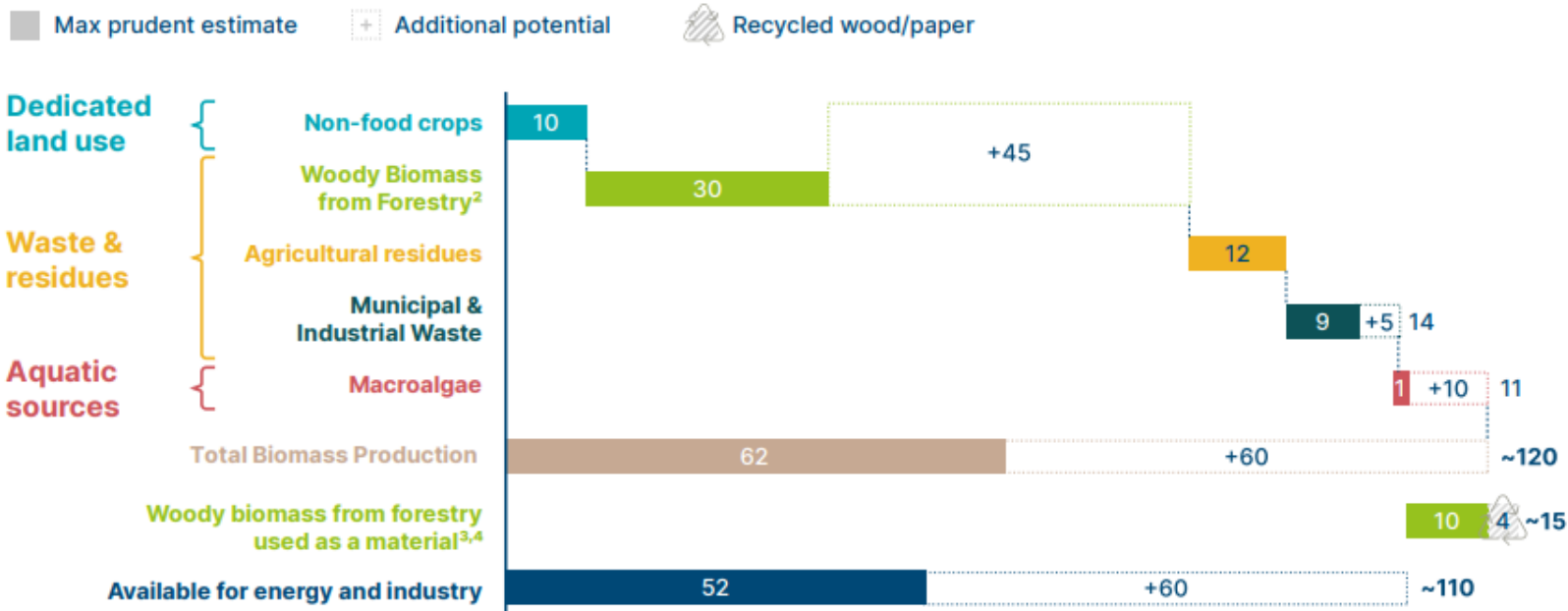

<sup>1</sup> The term 'sustainable biomass' is used to describe organic material that is renewable, has a life-cycle carbon footprint equal or close to zero (including considerations for the opportunity cost of land), and for which the cultivation and harvesting practices used are mindful of ecological considerations such as biodiversity and health of the land and soil.

<sup>2</sup> Includes high-quality stemwood from forestry suitable for the timber and pulp & paper sectors (~10 EJ/year today, FAO Industrial Roundwood production less by-products used for energy).

This category also includes residues from forestry but excludes traditional fuelwood (~25 EJ/year today, assumed to reduce with modernisation) due to collection and sustainability assurance challenges.

<sup>3</sup> E.g., timber, pulp & paper. Based on current harvests from commercial forestry; may increase if forestry additional high-quality stemwood could be made available if freed up land were dedicated to forestry.

<sup>4</sup> Additional supply from recycled materials (~4 EJ/year today).

SOURCE: SYSTEMIQ analysis for ETC (2021).

- Only 11% of timber today is certified as sustainably harvested
- 85% of this is from Europe, North Asia and North America
- Demand for sustainable biomass in a net-zero economy greatly exceed scenarios of maximum supply
- Crucial to prioritise use across sectors where it can be used as a material, in aviation and in applications where it can be combined with CCS



# Hybrid construction where timber is used to substitute a portion of steel/cement/concrete use has a lot of potential

## Cross-laminated timber + concrete hybrid floorplate system

### Concrete

- Lower susceptibility to vibration
- Better basic sound insulation

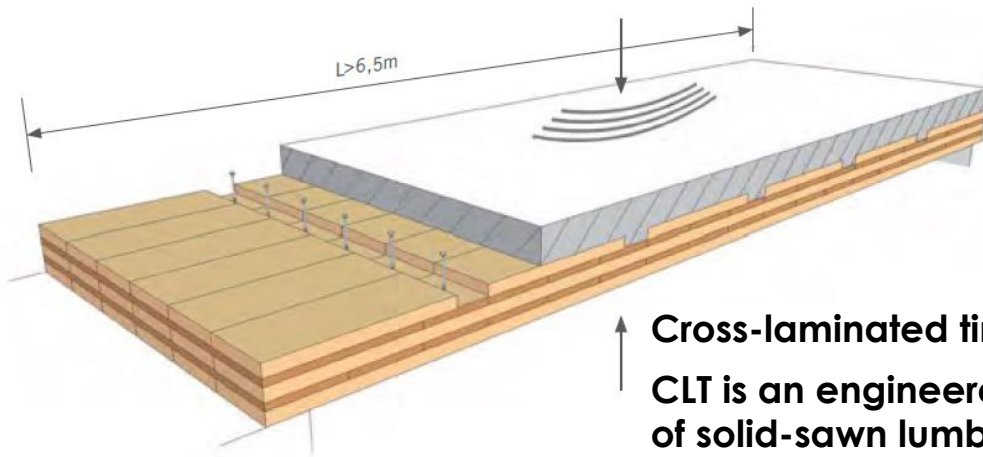

### Cross-laminated timber (CLT)

**CLT is an engineered wood product made by gluing layers of solid-sawn lumber together.** Key advantages include

- Non-combustible residual cross-section
- Higher strength and dimensional stability
- Greater impermeability

Hybrid construction can provide a balance between lower embodied carbon and other trade-offs:

- Durability and stability
- Fire and safety risks
- Sound and acoustics

# Efficient construction methods and circularity approaches help streamline building processes, reduce material waste, and reduce overall carbon



## Efficient construction methods

Use fast and efficient building techniques, to reduce time, labour, and material waste

- **Modular construction (deep dive available)**
- Digital tools (e.g., 3D printing, digital twin, building information modelling)
- Robotics and drones for material handling



**1% reduction  
in cement & concrete demand to 2050**



## Circularity approach

Implement re-use and recycling strategies to maximize the lifespan of materials and minimize waste in the construction process

- On-site waste management
- Recycling and re-use



**5% reduction  
in steel demand to 2050**



# Modular construction can reduce on-site emissions as well as minimise wastes

**Modular construction** is a building method where **parts of a building are made in a factory**, then shipped to the site and put together like big building blocks. It's faster and can be more efficient than traditional building methods



## Reduce construction waste

- The Modular Building Institute reported that modular construction can result in a **material savings of up to 20%** and **reduce on-site waste up to 90%**



## Cut transportation emissions

- Transporting fully constructed modules requires fewer trips compared to the transportation of raw materials for on-site building



## Use less energy on-site

- Average reduction in energy consumption of about **67%** during the building phase
- Projects are completed **twice as fast**

# Re-use and recycling have substantial material and emissions savings compared to producing virgin materials

## Cumulative material and emissions savings from implementing circular renovation actions on the EU building stock

Mt of material savings / Mt CO<sub>2</sub>e of emissions savings; 2022 to 2050

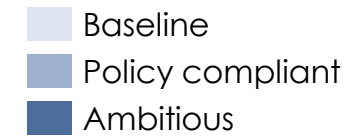

Material savings (Mt)

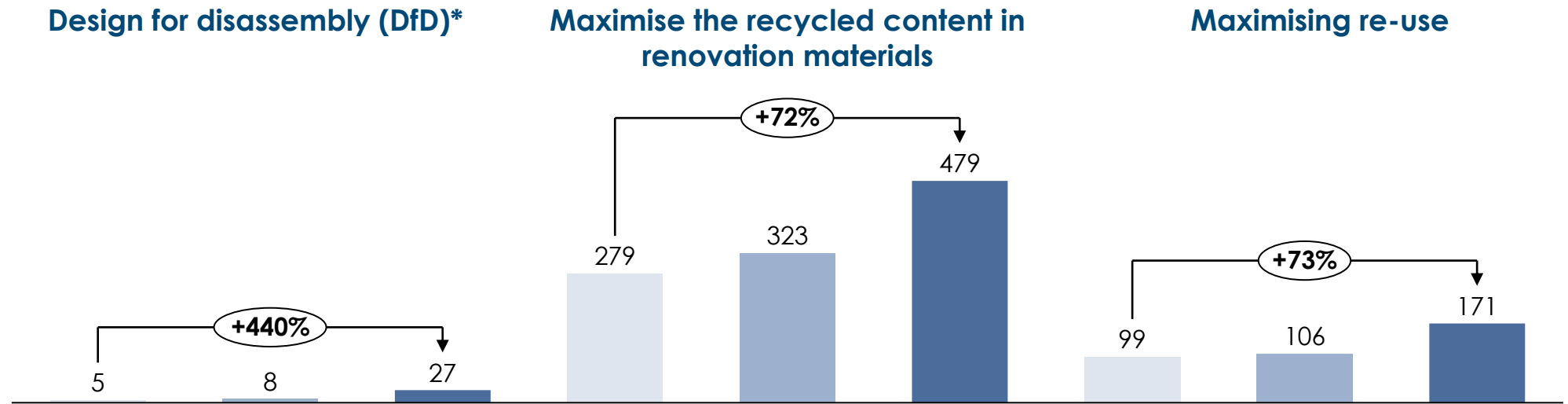

GHG emissions savings (Mt CO<sub>2</sub>e)

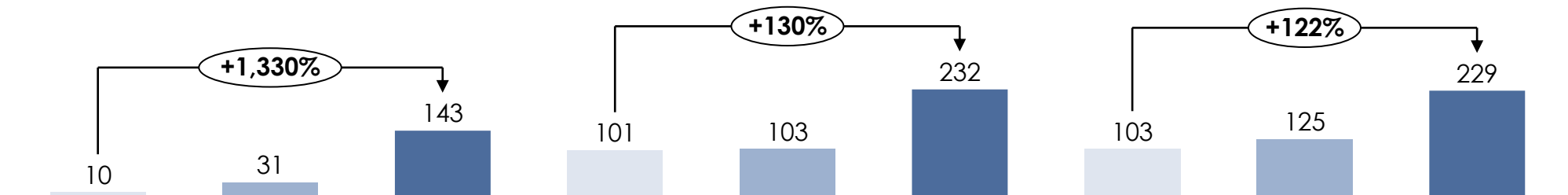

Note: \*DfD is a building design process that allows for the easy recovery of products, parts and materials when a building is disassembled or renovated

Source: European Environment Agency (2022), *Building renovation: where circular economy and climate meet*



# 'Build clever' and 'build efficient' levers can also be applied to other types of construction, such as roadway infrastructure

## Design choices: reduced lane configurations

Consider **narrower lanes or shoulders** where traffic volume allows. This directly reduces asphalt and concrete needs

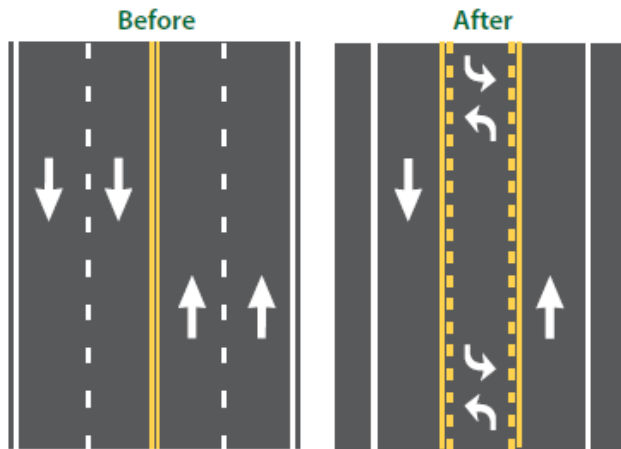

4-lane to 3-lane design

## Design choices: parking space

Parking spaces below a building can save a substantial amount of materials in walls



## Circularity approach: recycled asphalt pavement (RAP)

RAP is produced by combining with new and usable asphalt and aggregate from old roads to meet roadway specifications once again. The RAP in this new roadway **reduces the amount of required virgin material inputs and energy required**

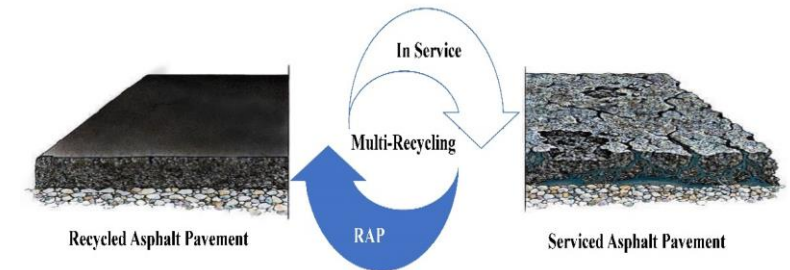

# Extending building lifetimes should be a priority in parts of Asia, where poor urban planning during rapid urbanisation has resulted in very low building lifetimes

## Building lifetimes vary massively:

- 50-60 years in the US
- Over 100 years in Europe
- 30-40 years in Japan
- 25 years in China → reflects inadequacy and inflexibility of buildings built during rapid urbanisation

**Potential to extend lifetimes is heavily region specific**

- Frequent demolition in Asia is often not due to poor construction quality
- Due to evolving urban planning and land policies → huge opportunity to get this right first time around
- For poor quality housing with high operational energy requirements, there is less opportunity

## Key levers:

- Better urban and spatial planning
- Material durability
- Regular maintenance
- Design and built with future uses in mind



**5% reduction  
in cement & concrete demand to 2050**



**10% reduction  
in steel demand to 2050**



# MPP analysis suggests that strategies to reduce material demand, minimise waste and extend building lifetimes could cut demand for cement and steel by 30-35% to 2050

## Potential percentage reduction in demand for cement and steel to 2050 with material efficiency and substitution levers

% material demand, cumulative to 2050

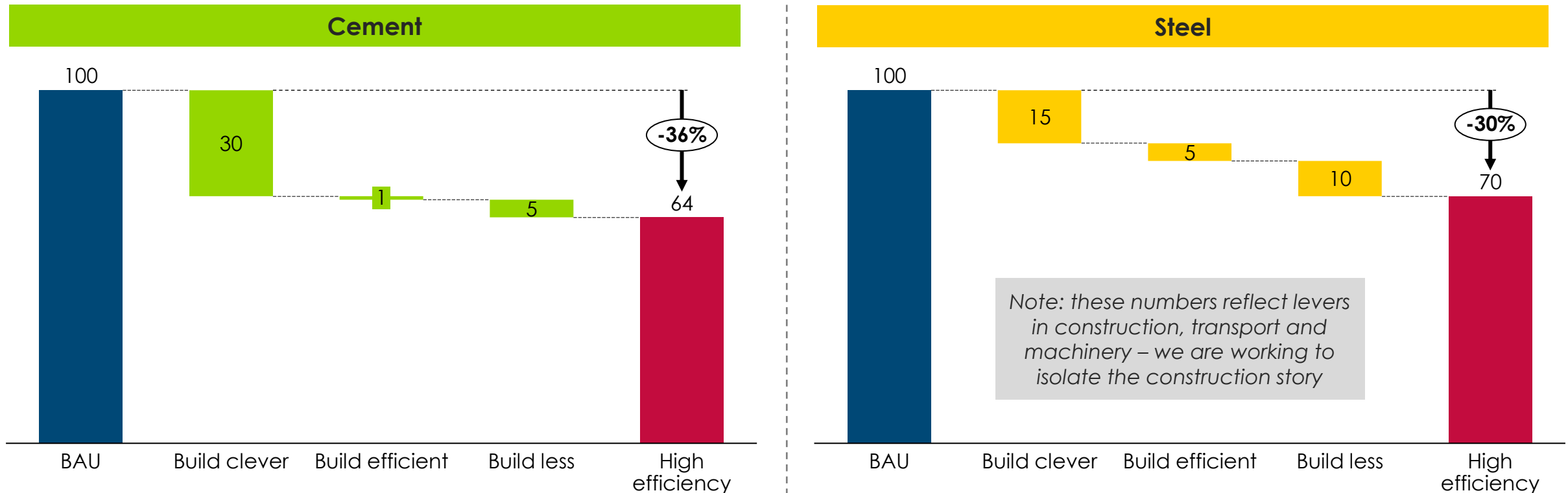

**Build clever:** Building design choices; Innovative construction solutions; material substitution

**Build efficient:** Efficient construction methods; circularity approach

**Build less:** extend building lifetimes



# The MPP strategies evidence the importance that material efficiency levers will play to reach net zero – but can these go further?

## Net zero, 1.5 degree aligned concrete and cement sector

GtCO<sub>2</sub> / year

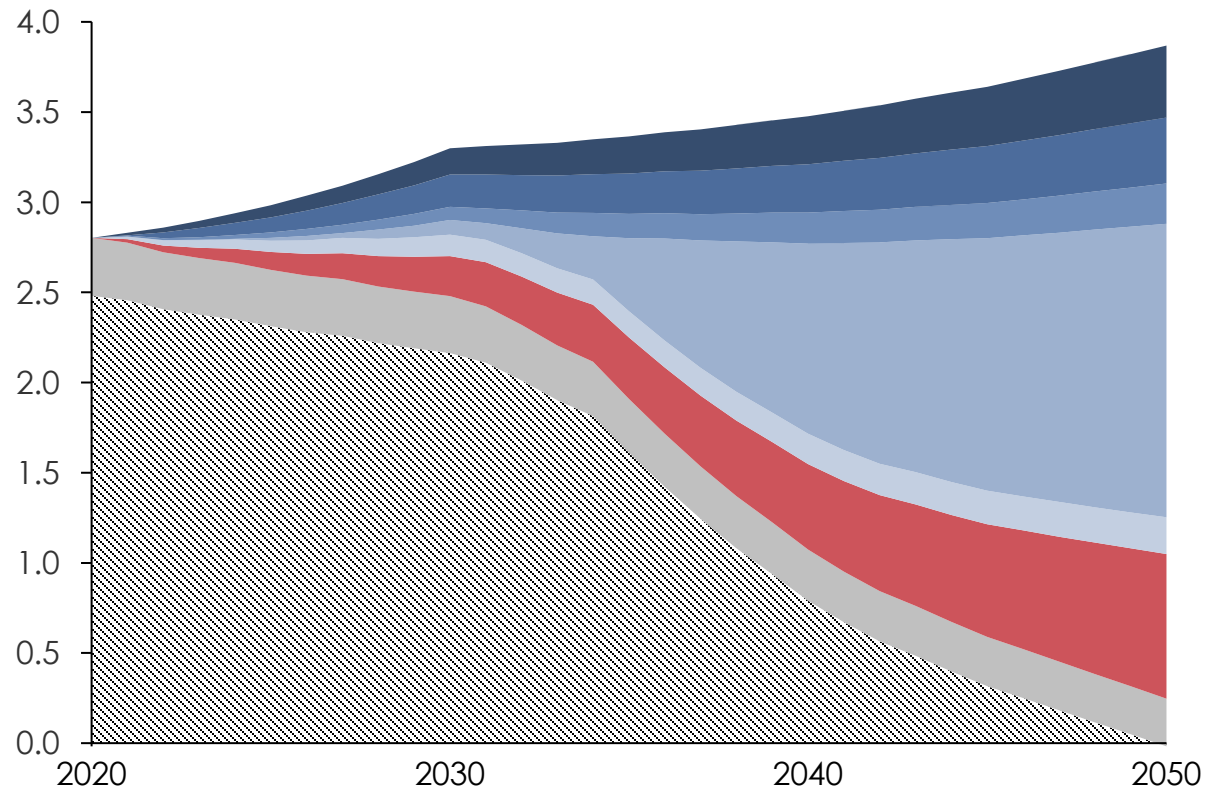

## Net zero, 1.5 degree aligned steel sector

GtCO<sub>2</sub> / year

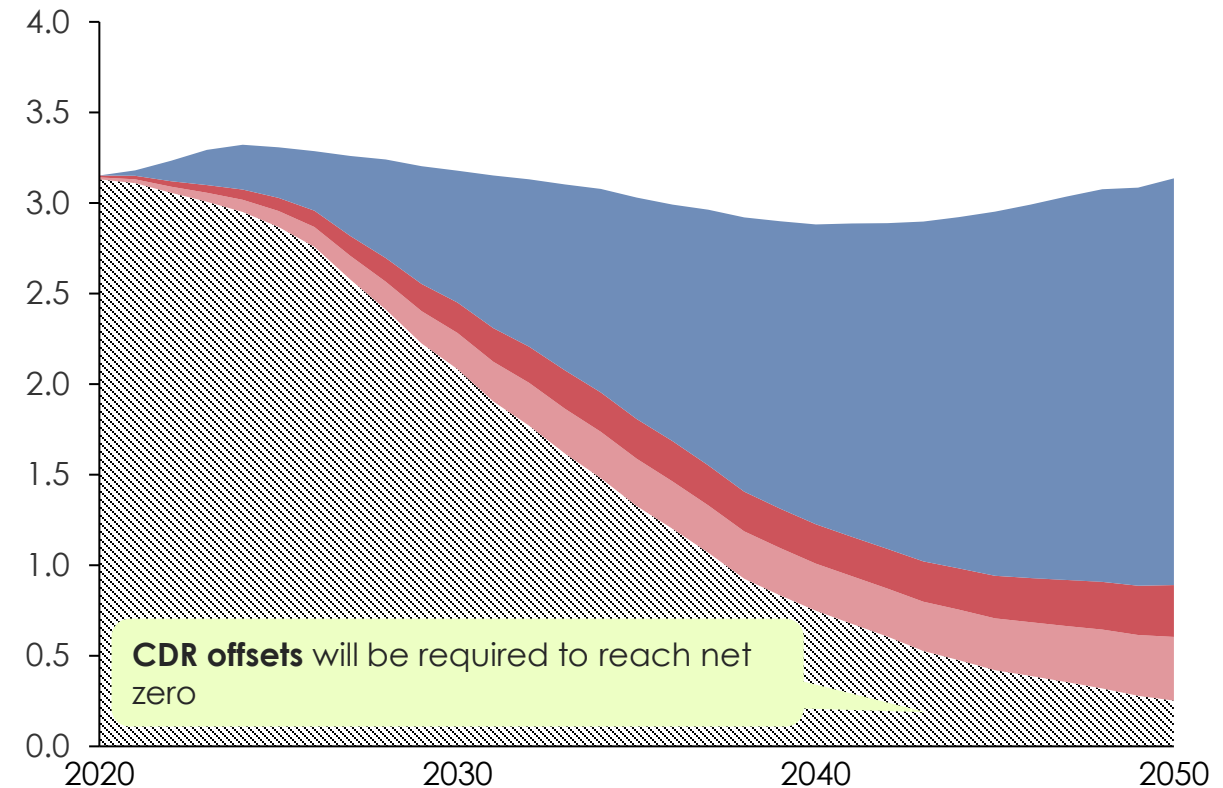

Source: Mission Possible Partnership (2023), *Making Net Zero Concrete and Cement Possible*; Mission Possible Partnership (2022), *Making Net Zero Steel Possible*

# Building less through efficient spatial design in residential developments, such as building multi-unit houses, is key to reducing embodied carbon from buildings and infrastructure

## Emissions saving potential of space efficiency in new-building during one year, EU

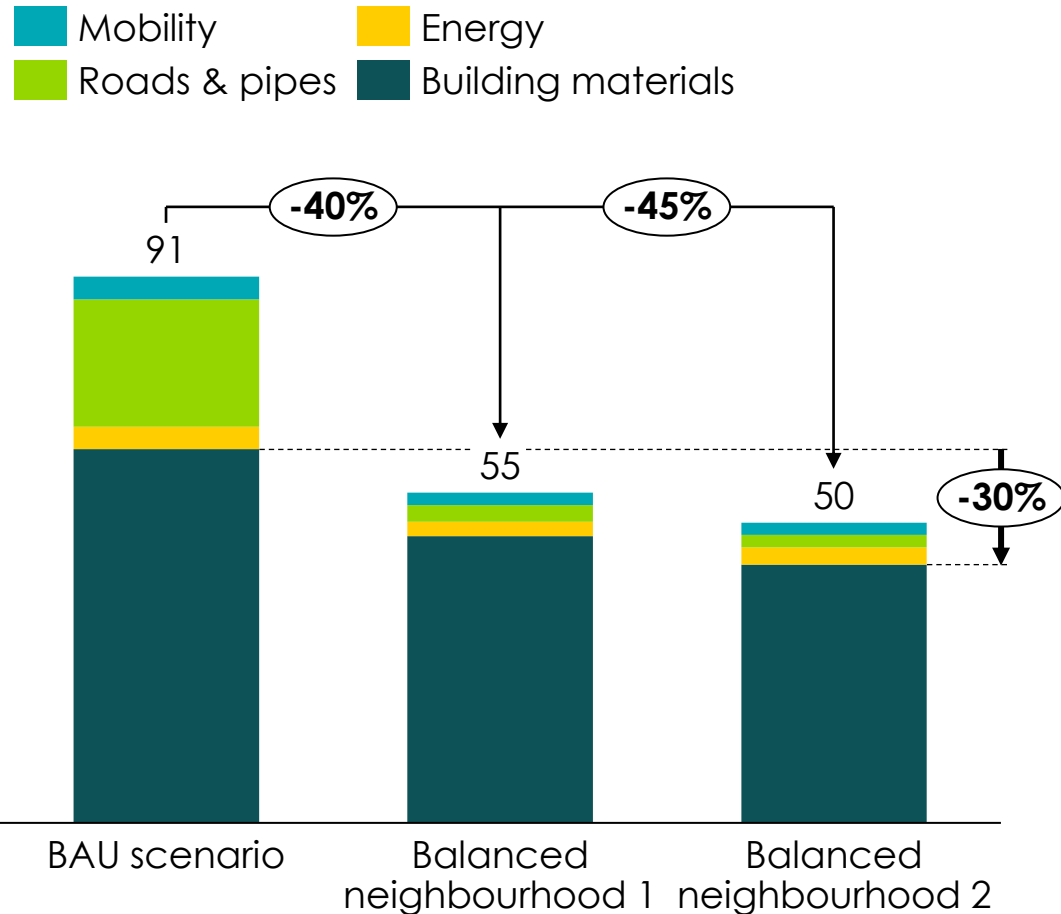
Mt CO<sub>2</sub>

BAU Scenario

50% of new developments are single-unit houses in expanding low-density settlements (requiring new roads and utilities). 50% are multi-unit houses. 25% of newbuilds are infill



Balanced neighbourhood scenario 1 – better new building

All new developments are spacious multi-unit houses and 75% infill (no new roads or utilities required)

Balanced neighbourhood scenario 2 – better new building + better use of existing buildings

Scenario 1 assumptions + better use of un(der)-occupied buildings, avoiding 10% of newbuild

# Ambitious scenarios to limit floor space per capita suggest build out could be 15% lower; but achieving this relies on significant lifestyle and behavioural changes

## Scenarios of the expansion of global floor space in 2050

Billion m<sup>2</sup>

- Commercial buildings
- Residential buildings

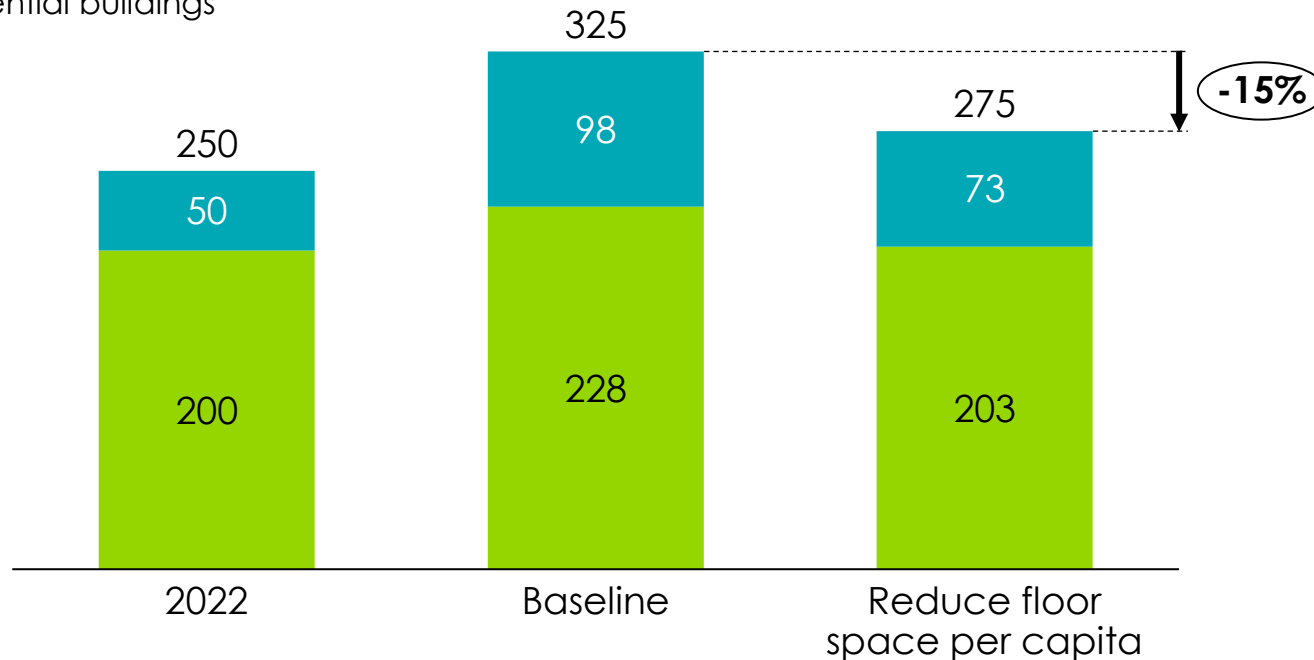

Global average m <sup>2</sup> / capita	Residential	Commercial	Total
	20.0	5.0	26.6
	26.6	11.1	23.7
	23.7	8.1	23.7

### Key potential for reduction:

- Reduction in residential and commercial floor space per capita in North America and Europe → opportunity due to shrinking populations and fewer second homes
- Huge opportunity to reduce vacancy rates in China
- Limited potential to reduce m<sup>2</sup>/capita in developing countries; levels remain far below Europe/N America average

### But how feasible to achieve these reductions?

- Relies on lifestyle and behaviour changes
- Does not necessarily lead to lower wellbeing → lower vacancy rates, shared working spaces, telecommuting, urban vs rural living, multi-family homes vs single-family homes

# The biggest opportunity to reduce the growth in floor space is in China, where the built environment already exceeds need

## Growth in global floor area by region

2022-2050; Billion m<sup>2</sup>; IEA NZE Scenario

- Other middle and low income countries
- China
- High income countries

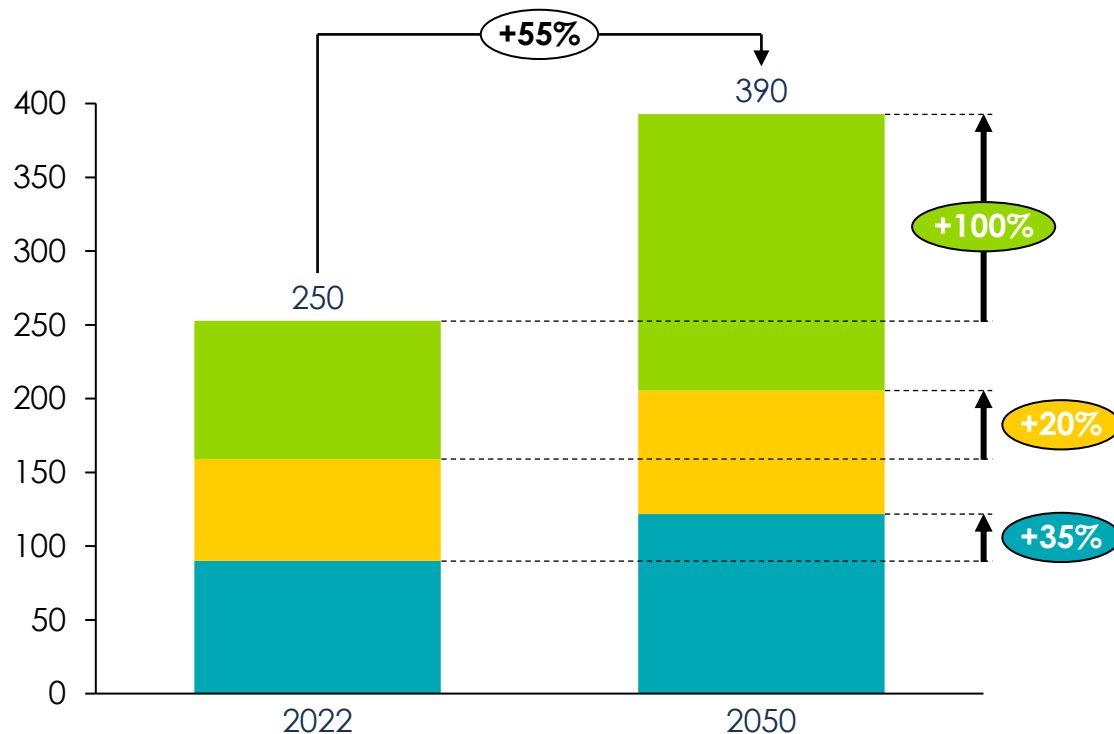

### The buildings + infrastructure embodied carbon opportunity in China: reducing significant wasted investment

- 40% of Chinese urban households own two or more apartments
- Vacancy rates exceed 20% in most cities
- In many cases, new buildings will never be occupied
- Urban infrastructure in many third and fourth-tier cities massively exceeds future requirements

→ Huge potential to reduce projected growth in floor space

Sources: IEA 2022. Chart: Evolution of global floor area and buildings energy intensity in the Net Zero Scenario, 2010-2030; ETC and RMI (2020), Achieving a green recovery for China

# Material efficiency and substitution levers could further reduce cumulative embodied carbon of new buildings to 2050 by 10%; a 60% reduction overall is therefore within reach

Potential reduction of baseline embodied carbon from decarbonising material inputs, cumulative emissions 2023-50  
Gt CO2e

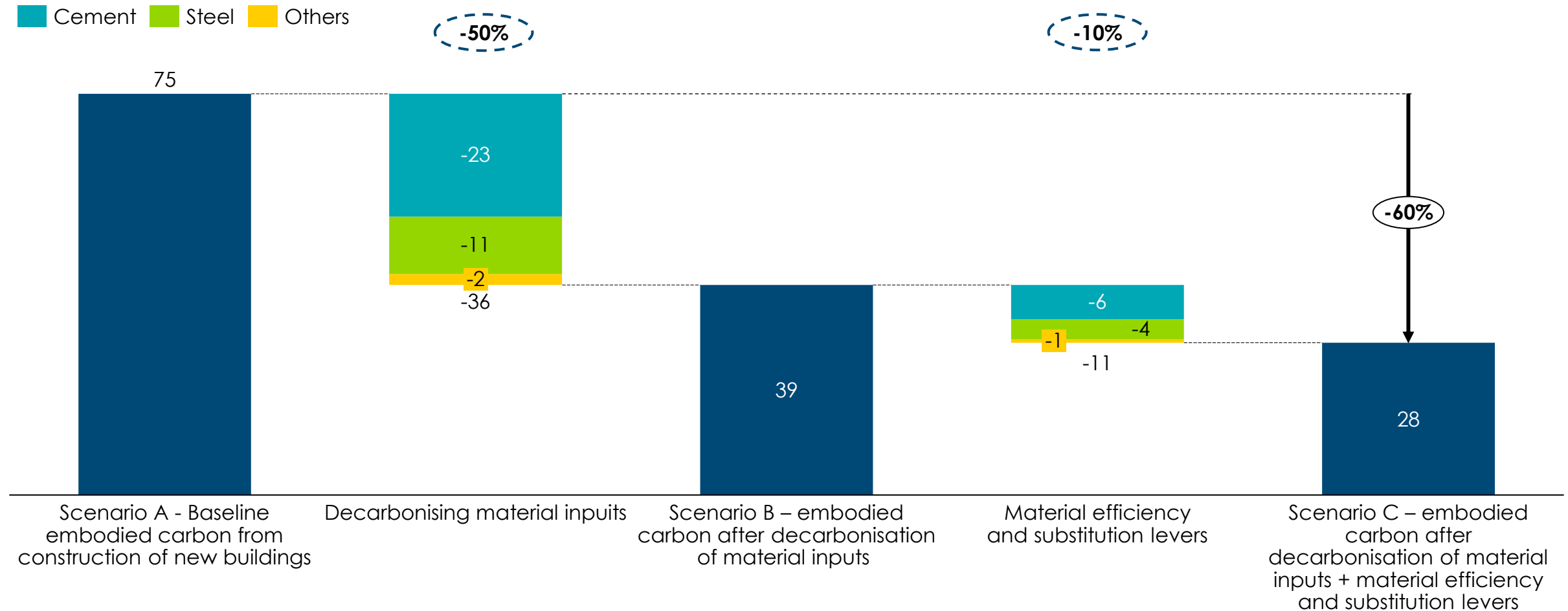

Note: \*Assuming productions of other materials will decarbonise at the rate of how aluminium production decarbonises, and the efficiency and substitution rate as steel rate  
Sources: Systemiq analysis for ETC (2024)

# 3. Decarbonising in-use and end-of-life embodied carbon



# Embodied carbon: decarbonising material inputs

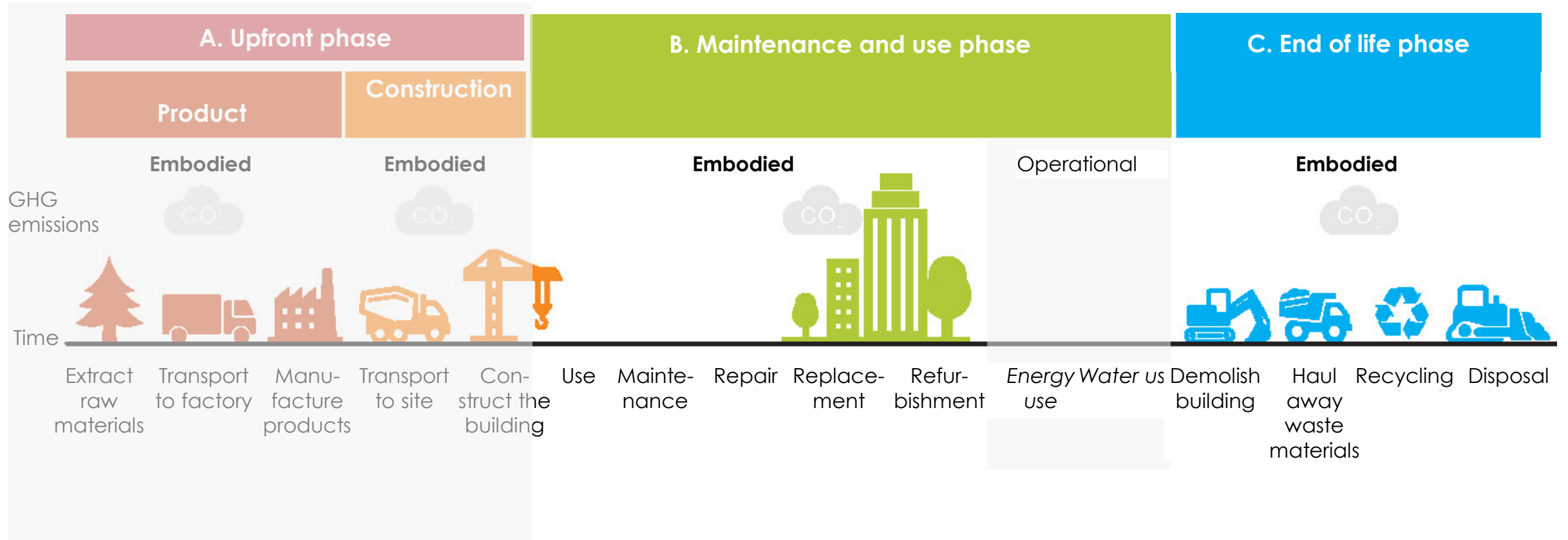

Source: New Buildings Institute, *Embodied Carbon*

# The key consideration for the embodied carbon of retrofits is the extent to which they realise a reasonable carbon payback from lower operational energy use

## Illustration of carbon payback to energetic retrofit

CO2 emissions

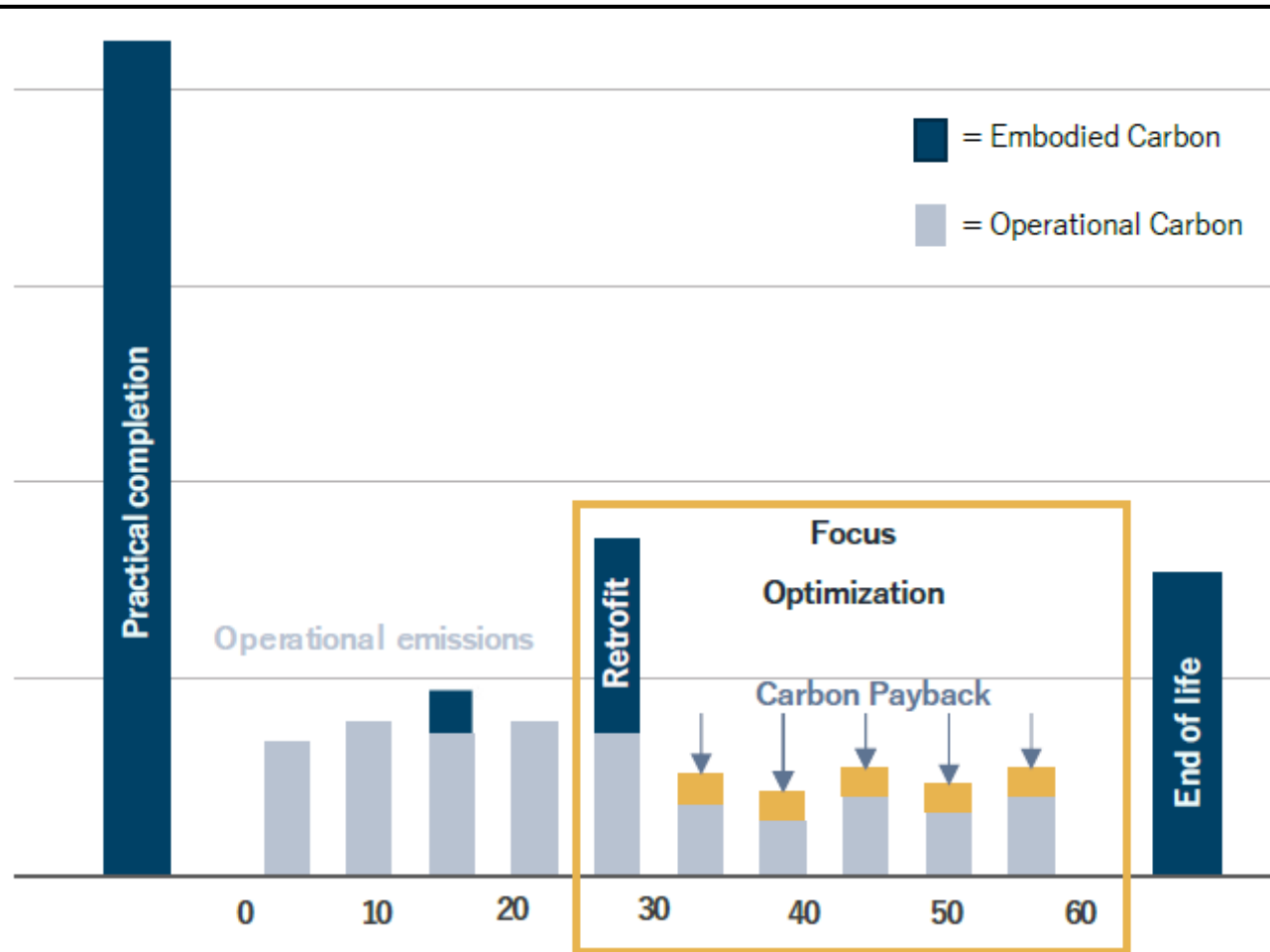

**Energetic retrofit:** any measure which improves the energy efficiency of a building and reduces operational energy use

But as heating is electrified and the grid is decarbonised, how does the carbon payback worsen?



# At today's electricity carbon intensities, even deep retrofits have a reasonable carbon payback; but this will change with renewables-dominated electricity grids

## Estimated carbon payback at different types of retrofit and carbon intensity of electricity

Years, estimates for a 100m<sup>2</sup> house

Carbon payback (years)	600gCO <sub>2</sub> /kwh	300gCO <sub>2</sub> /kwh	75gCO <sub>2</sub> /kwh	10gCO <sub>2</sub> /kwh
Retrofit type	<i>China, Australia</i>	<i>US, Germany</i>	<i>Finland, France</i>	
<b>Light</b> 15kgCO <sub>2</sub> /m <sup>2</sup>	1 year	2 years	8 years	60 years
<b>Medium</b> 40kgCO <sub>2</sub> /m <sup>2</sup>	1.5 years	2.5 years	11 years	80 years
<b>Deep</b> 85kgCO <sub>2</sub> /m <sup>2</sup>	2 years	4 years	15 years	115 years



**Decreasing payback as the electricity grid decarbonises**



Source: Systemiq analysis for the ETC (2024); CRREM (2023), *Embodied Carbon of Retrofits*.

Note: analysis focused on all-electric households with an annual energy consumption of 15,000 kwh in the baseline scenario; energy savings from light retrofit (15%), medium (30%), deep (50%)

# The carbon payback to retrofits can be improved with similar strategies to reduce the embodied carbon of material inputs

## Embodied carbon of common insulation materials

kg CO2/kg of material

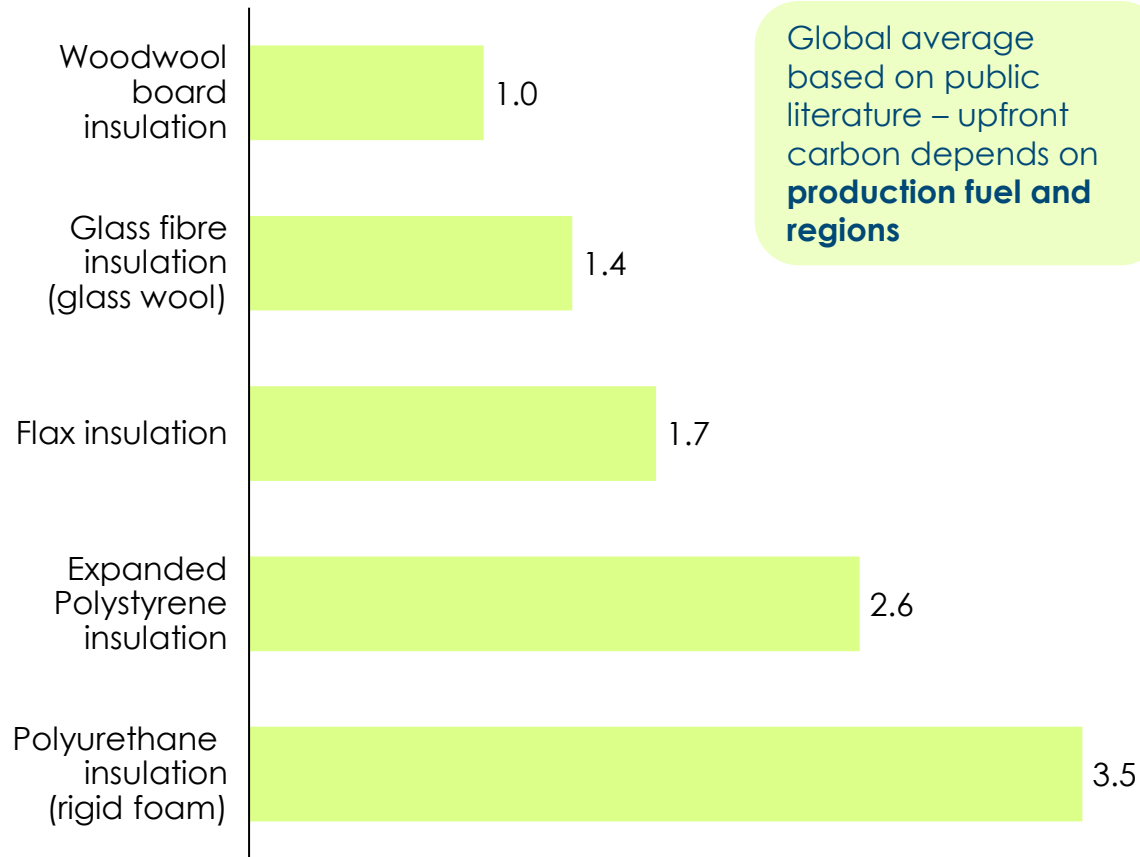

## Key levers to reduce embodied carbon of retrofits:

- Prioritise lower-carbon materials (e.g., natural fibres)
- Use materials with recycled content
- Consider durable materials which will last longer and reduce the frequency of retrofit
- Prioritise local materials

**For many retrofits, the value goes beyond carbon and energy bills – but is key to improving living standards, health and reducing inequality.**



Source: GreenSpec, Embodied Carbon & EPDs

# Retrofitting generally has lower embodied carbon than rebuilding, but building from scratch allows for optimal design and operational performance



## Renovation/Retrofitting



## Building from scratch



Arguments  
for

- **Reduced material use and embodied carbon:** renovating or retrofitting existing buildings typically requires less new material, thus generating lower embodied carbon
- Other considerations include **heritage and culture preservation** and potential **upfront cost savings**

**Lower operational carbon:** new constructions can achieve higher standards of energy efficiency, reducing operational carbon emissions over the building's lifecycle

- **Optimized design:** incorporating the latest advanced building technology and sustainable practices and materials from the ground
- **Regulatory compliance:** Easier to meet or exceed increasingly stringent building codes and standards



Arguments  
against

- **Complex and limited improvements** due to inherent design and structural limitations
- Even when retrofitted, may still have **higher operational energy demands**

- Constructing new buildings involves significant **higher embodied carbon**
- **Demolishing** existing buildings to make way for new ones **generates substantial waste**



# Case study: Schneider Electric IntenCity building

Pre-read only



IntenCity building is Schneider Electric's new flagship building located in the Scientific Polygon of Grenoble, France. Through an in-depth **Whole Life Cycle Analysis** of the building, SE concludes that the cumulated carbon footprint of IntenCity is **5 times less** than an average European building on a 60-year life with **less than 5%** of its total cumulated carbon emissions coming from operations

Schneider Electric further compared 2 scenarios and perform the WBLCA analysis per year, per m<sup>2</sup> – on a life cycle of 60 years

- Scenario 1: **Retrofitting** of 5 existing sites, some of the former Schneider Electric Grenoble sites, to achieve higher energy performance
- Scenario 2: **Erecting a new Building**

In the local context, and specifically for this project, **building right from scratch emits as much as renovating sites over a 60-year lifetime**

# However, if best practices and energy efficiency efforts are prioritised, rebuilding could emit as much as retrofitting from a life cycle point of view

## Average cumulated carbon emissions from retrofitting

kgCO<sub>2</sub> e/m<sup>2</sup> over 60 years

## Average cumulated carbon emissions from building new

kgCO<sub>2</sub> e/m<sup>2</sup> over 60 years

■ Upfront embodied carbon ■ In-use embodied carbon ■ Operational carbon

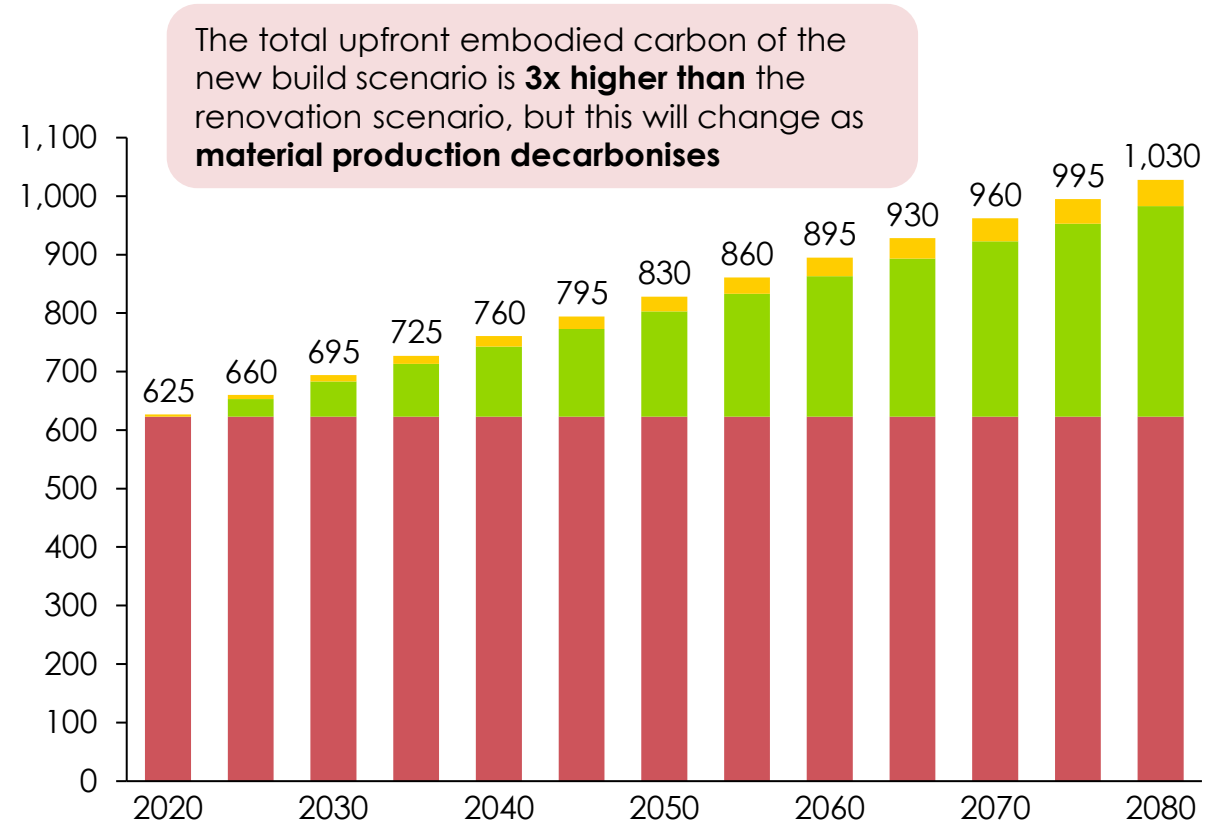
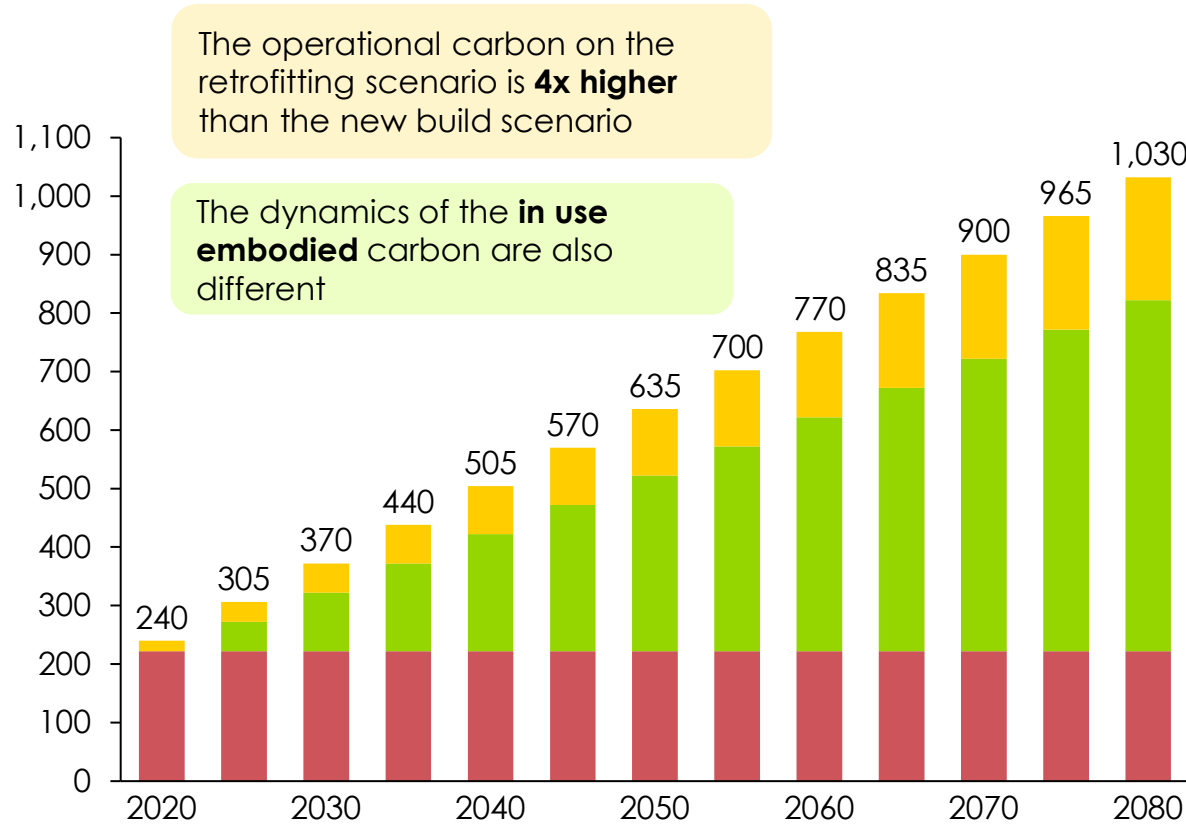

Source: Schneider Electric Sustainability Research Institute (2023), *Towards net-zero buildings: Exploring the IntenCity case*

# 4. Barriers and solutions



# Key messages – the embodied carbon challenge

- Embodied carbon is often overlooked, but can account for up to half of a building's lifecycle emissions
- As heating is electrified and electricity grids are decarbonised, embodied carbon will become an even bigger share of emissions
- By far the biggest source of embodied carbon is from the production of material inputs to construction, namely cement, concrete and steel – this means that by far the most important lever is the decarbonisation of these materials (as well as aluminium, bricks, and glass)
- In recent years, the Mission Possible Partnership's sector transition strategies have challenged the belief that it was not possible to fully decarbonise the so-called "hard to abate" sectors by 2050, setting out the suite of technologies available today as well as material efficiency levers to reduce demand
  - The analysis shows that levers to reduce emissions in the production of materials (e.g., new technologies such as CCUS, switching to alternative fuels (e.g., hydrogen), and clean electrification) are by far the most important
  - However, material efficiency and substitution levers are crucial to reaching net zero by 2050, and are also possible to scale up this decade – driving important progress to reducing emissions while technologies such as CCUS will not significantly scale until the mid 2030s
- With global floor area set to more than double by 2050, action to reduce embodied carbon during the transition is critical; new construction could release 75GtCO<sub>2</sub>, or 40% of the remaining carbon budget for 1.5C.
- There are a huge variety of strategies that can be deployed in the brief, design and construction phases to reduce the use of high-carbon material inputs.
  - Developers, construction companies, and policymakers / urban planners should deploy a mixture of strategies to build nothing (e.g, better use of existing space), build less (e.g., extending lifetimes), build clever (e.g., material efficiency and substitution) and build more efficient (e.g., reduce waste in construction).



# Key messages – material efficiency and substitution levers

- While material decarbonisation takes time, developers can make strategic design and material choices which either use less material inputs or substitute high-carbon materials for lower-carbon inputs.
  - Building design and construction choices, such as concrete waffle slabs, and material substitution to low-carbon alternatives can reduce cumulative concrete, cement and steel demand to 2050 by 15-30%
  - Efficient construction which reduces waste, such as modular construction, is expected to have a lower relative impact of around ~5% reduction in material demand
  - Strategies to build less (e.g., extending building lifetimes especially in Asia) has the potential to reduce material demand by 5-10%.
  - Realising the potential of these levers requires skills and knowledge of developers and architects, where awareness of solutions remains low, commitments from developers to reduce embodied carbon and therefore pursue strategies even where they add to design complexity, and full consideration of the trade-offs with operational energy/carbon.
- The biggest potential to reduce embodied carbon is in the brief stage, i.e. deciding whether to build at all. Ambitious strategies suggest that global floor space could be 15% lower in 2050, with shrinking populations and teleworking in Europe and the US limiting floor space per capita.
  - In China, there is a huge opportunity to optimise existing floor space, with vacancy rates of over 20% in most cities and very high second homeownership.
  - However, strategies to reduce build rates ultimately rely on lifestyle and behaviour change, which is hard to achieve.
- For existing buildings, in most cases it is better to retrofit than to build new, and carbon benefits of retrofits are strong, though set to decline as the grid decarbonises. In a small subset of buildings building new from scratch may significantly improve energy consumption



## Key messages – barriers and solutions

- Higher costs of low-carbon steel and cement through to 2050 will create an incentive for developers to consider material efficiency and substitution strategies to reduce input use.
- Demand for “green” buildings is growing, but the main focus to date has been on operational carbon, given this is relatively easier to understand, measure and define targets for; green building certifications often overlook it
- This means that market demand signals for low embodied carbon buildings are weak
- As the private sector sets emission reduction targets, voluntary action to take action on embodied carbon will increase; but challenges to incorporate embodied carbon in targets will hinder progress.
- Regulation needs to play a role, but setting minimum standards will be much harder than for operational carbon, where clearer benchmarks and measurement exist
  - For embodied carbon, there are many complex trade-offs (e.g., with safety, operational energy, durability) which regulation needs to ensure does not create unintended consequences for
  - In addition, if regulation is too specific, it can be a barrier to innovation
  - Regulation should focus on mandating carbon intensities for material inputs, including minimum recycled content for material inputs, and requiring all new buildings undertake whole lifecycle emission assessments.



# The MPP strategies outline the suite of policy and private sector levers required to scale low-carbon cement and steel

Summary of high-potential solutions to address the three key challenges to decarbonise the sector

EXHIBIT 3.2

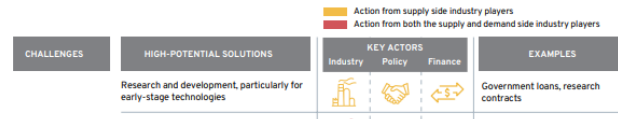

**Accelerating the adoption of low-carbon methods and technologies in the concrete and cement sector**

CHALLENGES	HIGH-POTENTIAL SOLUTIONS	KEY ACTORS	EXAMPLES
	Research and development, particularly for early-stage technologies	Industry, Policy, Finance	Government loans, research contracts
	Performance-based concrete standards supporting testing measures		
	Plant-level pathways to targets and interim milestones		
	Standardised definition methods for zero-emissions concrete		
	Policy mandate on the use of concrete		
	Policy mandates or incentives to accelerate the market from bagged to bulk cement		

Example solutions to address barriers to decarbonisation in the aluminium sector

EXHIBIT 3.2

Problem	Problem statement	Potential solutions	Examples
Access to low-carbon power	Smelters do not have access to low-carbon power	Long-term planning for policy transition Shared infrastructure provision including low-carbon power	EGA and GE Power decarbonisation roadmap

Four key challenges to kick off the transition to net-zero steel in this decade and a non-exhaustive overview of potential high-impact solutions

EXHIBIT 3.2

Problem statement	High-potential solutions	Policy	Industry	Finance	Customers	Examples
<b>TECHNOLOGY</b>						
Near-zero-emissions primary steelmaking technologies have yet to become commercially available	Support R&D, particularly for earlier-stage technologies Incubate pilot projects in locations with favourable conditions (such as access to cheap renewable energy)	✓	✓	✓	✓	• The HYBRIT project for hydrogen steelmaking in Sweden • Government loan guarantees
Near-zero-emissions primary aluminium cannot be produced without a green premium	De-risk near-zero-emissions projects with public-private partnerships Arrange "anchor" off-take agreements for breakthrough projects	✓	✓	✓	✓	• Blended finance involving development banks • SteelUniversity, an initiative of worldsteel
<b>ENERGY AND SUPPORTING INFRASTRUCTURE</b>						
The energy and carbon infrastructure needed to underpin a net-zero steel industry is not yet in place	Legislate low-carbon electricity scale-up, alongside decarbonisation of power sector Channel capital towards clean energy and CO <sub>2</sub> infrastructure projects Forge cross-value-chain partnerships to position clean steel production as an "anchor" off-taker for clean energy or CCUS infrastructure	✓	✓	✓	✓	• Public targets and support for clean electricity build-out, such as the Renewable Energy Directive of the European Union and the Inflation Reduction Act in the United States • Identification of prospective new industrial "hubs" centred on hydrogen or CO <sub>2</sub> pipelines and storage
<b>COST</b>						
Near-zero-emissions steel is likely to face a green premium for the foreseeable future	Agree forward purchase commitments for the long-term off-take of near-zero-emissions steel at a premium to send clear demand signals to the market Institute green public procurement requirements for steel Introduce carbon markets through appropriate regulatory measures	✓	✓	✓	✓	• Demand-side initiatives such as First Movers Coalition (FMC) in the United States and SteelZero • The green public procurement commitments developed by countries party to the Clean Energy Ministerial (CEM) Industrial Deep Decarbonisation Initiative (IDDI) • Carbon pricing regimes (set by emissions trading schemes or alternative regulatory measures) potentially supported by carbon contracts for difference (CCFDs)
<b>COMPETITION</b>						
Varying steel abatement costs across regions can create competitive distortions	Set joint definition of near-zero-emissions steel Adopt policy mechanisms to counteract competitive distortions Establish multilateral agreements between major steel-producing countries Apply climate-aligned investment principles to steel financing (including collective frameworks)	✓	✓	✓	✓	• Standards designed by ResponsibleSteel • Applying carbon border adjustment mechanisms such as the one put forward by the European Union • The Sustainable STEEL Principles for climate-aligned investment developed by the RMI Center for Climate-Aligned Finance

Source: MPP analysis

## Key levers:

- Carbon pricing
- Mandates on recycled content and low-carbon percentage
- Offtake agreements
- Green procurement
- Industry consortia to share risks and learnings
- R&D support
- Development of shared infrastructure + clean electrification



# Higher costs of low-carbon steel and cement will only add ~1.5-3% to construction costs, but could spur developers to explore material efficiency and substitution strategies

## Levelised cost of steel in 2050

\$/t

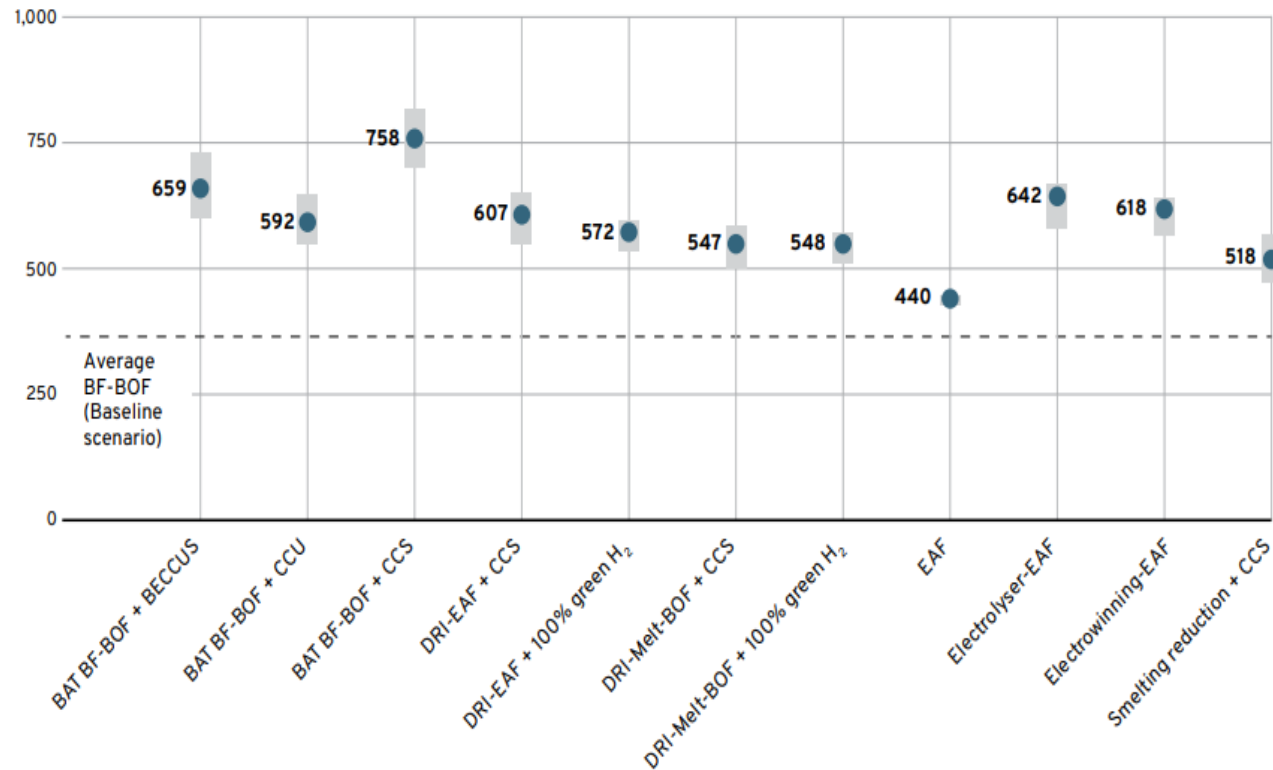

Low-carbon steel costs might be 2x higher, but as steel is only a portion of total construction costs, the percentage increase to building costs are expected to be:

**+ 1.5-2% to 2050**

Without policy support, cost increases expected:

- Cost of cement: + 40-120%
- Cost of concrete: + 15-40%
- **Cost of building: +1.5-3%**



Source: Mission Possible Partnership (2023), *Making Net Zero Concrete and Cement Possible*; Mission Possible Partnership (2022), *Making Net Zero Steel Possible*

# But cost incentives will not be sufficient to drive large-scale action on reducing material demand; voluntary commitments and regulation will be required to overcome key barriers

## KEY CHALLENGES:

### A. Awareness and demand

- The **tools and methods** needed to calculate embodied carbon are relatively **complex not well understood**
- **False perception** that embodied carbon is relatively **insignificant** compared to operational emissions
- A **lack of market demand** for low embodied carbon materials and construction methods

### B. Skills and capacities

- **Low investment in skills and capacity building** across the value chain
- Material efficiency strategies often more **complex** and **labour intensive**
- **Transparency and open collaboration** to share solutions and best practice are **limited**

### C. Policy and regulation

- Further **supply-side supportive policy** measures are still needed, including innovation funding and incentives for reuse and recyclability
- Barriers to demand side policy include **lack of awareness and demand** but also aspects of the political framework such as policy cycles and changing political priorities

### D. Technical considerations

- On the demand side, **a lack of high quality, robust data from LCAs** (life cycle assessment) and **EPDs** (Environmental Product Declaration) in some regions makes it difficult to set benchmarks and targets

### E. Finance / “making the business case”

- Financial incentives and products are almost **exclusively targeted at reducing operational carbon**
- For some low-carbon alternatives there is a **cost premium**
- Circular business models may be assessed as ‘higher risk’ by lenders and investors using **traditional risk criteria**

**A mix of voluntary commitments, regulation and policy incentives is required**

# Embodied carbon is rising up the policy agenda – the UN Climate Action Pathway and 2030 Breakthroughs set commitments to reduce embodied carbon by at least 40% by 2030



## Buildings Breakthrough target

“Near-zero emission and resilient buildings are the new normal by 2030”

- New buildings and deep renovation are both concerned
- “Near-zero emission buildings” are high energy-efficient buildings with a low carbon footprint taking into account a **whole life cycle assessment** approach (meaning using a low GHG energy source, and built with **low GHG building materials and equipment**)
- “Resilient Buildings” are buildings that integrate specifications related to the future climate in their design, construction, and operation maintenance
- “New normal” means the above concepts are generalized in engineered buildings





## Breakthrough outcome

100% of projects due to be completed in 2030 or after are net zero carbon in operation (with at least **40% less embodied carbon** compared to current practice)

The Buildings Breakthrough was officially launched at COP28 UAE, following the Breakthrough Agenda at COP26. It collectively represents **28 governments**, including China and United States, aiming at strengthening international collaboration on decarbonizing the built environment

# Industry groups are beginning to set voluntary commitments to reduce embodied carbon

Initiative	Description	Signatories
	<ul style="list-style-type: none"> <li>The Net Zero Carbon Buildings Commitment has 176 signatories equating to <b>~\$400 bn annual turnover</b></li> <li>2030 Commitment: <b>40% reduction in embodied carbon for new buildings, infrastructure and major renovations</b></li> <li>2050 Commitment: <b>Net zero embodied carbon for new buildings, infrastructure and major renovations</b></li> </ul>	<ul style="list-style-type: none"> <li>Asset managers/Funds</li> <li>Property Developers</li> <li>Real estate services</li> <li>Architects</li> <li>Construction companies</li> <li>Financial services</li> </ul>
	<ul style="list-style-type: none"> <li>The BBP Climate Commitment has 37 signatories that have <b>~\$400bn AUM</b></li> <li>Requires investors to publish their <b>2050 net zero pathways and delivery plans</b> including plan to reduce <b>embodied carbon of development, refurbishment and fit-out works</b></li> <li>The guidance recommends use of Science-Based Targets for setting net zero decarbonisation pathways and interim targets</li> </ul>	<ul style="list-style-type: none"> <li>Asset Managers</li> <li>Real Estate Investors</li> </ul>
	<ul style="list-style-type: none"> <li>Over <b>200 real estate companies and SMEs<sup>1</sup></b> have committed or set corporate net-zero Science-Based Targets so far</li> <li>Newly published sector-specific buildings guidance and pathway includes <b>discrete 2030 targets for upfront and in-use embodied emissions</b></li> </ul>	<ul style="list-style-type: none"> <li>Asset managers</li> <li>Property developers</li> </ul>

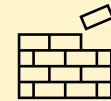

The **SBTi guidance and pathway for buildings** is the most comprehensive and robust approach for stakeholders to reduce embodied carbon in buildings so far

Notes: 1 Real Estate companies who set SBTs are a mix of investors, property developers and other companies related to the sector  
 Sources: WGBC (2023) The Commitment; BBP (2023) Member Climate Commitment; PCAF (2022) Accounting and reporting of financed GHG emissions from real estate operations; SBTi (2023) Target Dashboard; SBTi (2023) Buildings Sector Science Based Targets Guidance

# With corporate tenants and real estate investors setting emission reduction targets, demand for low embodied carbon buildings is expected to grow

## Corporate tenant Commitments

Supply and demand\* for low embodied carbon office space for London, Paris and Berlin today m2

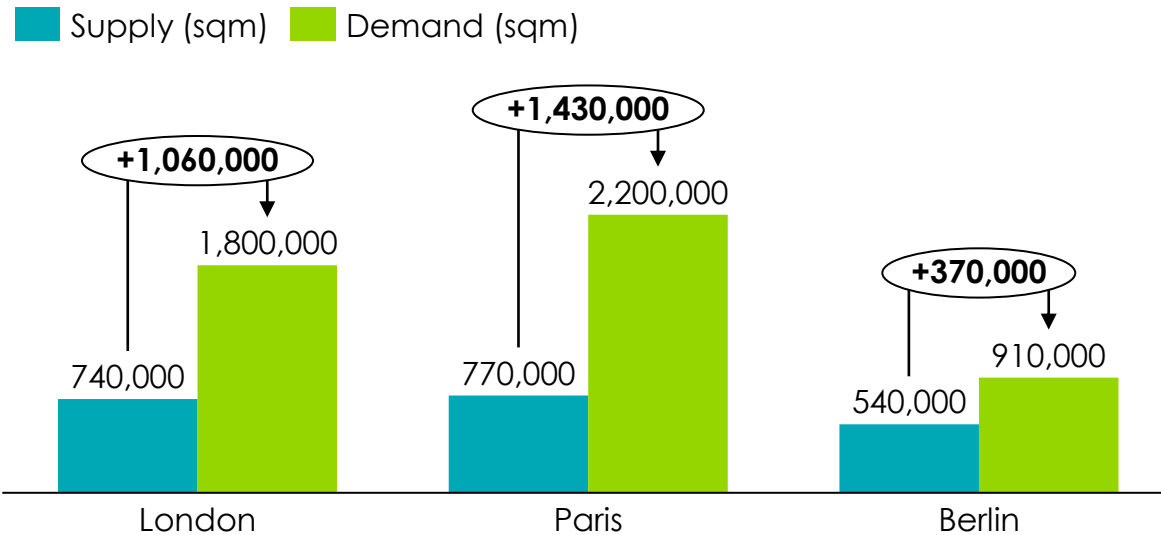

- Tenants committing to science-based targets expected to prompt **higher demand for lower embodied carbon offices** in the coming years to deliver on their 2030 target
- Demand for low embodied carbon office space expected to be at **~2 x higher** than supply in Europe and demand is expected to exceed supply by 10 x in the US

## But are tenants willing to pay more?

## Investor Commitments

Selected examples of Real-Estate Investors Scope 3 Absolute Emissions Targets Thousand tonnes CO<sub>2</sub>e

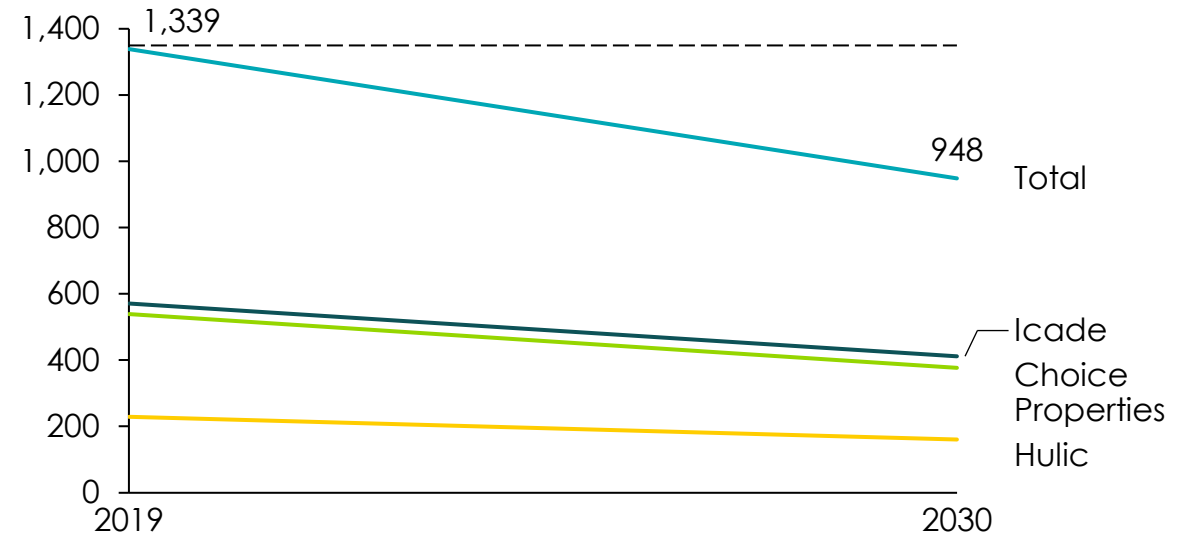

- Embodied carbon is generally part of the **scope 3 emissions for an investor**
- ~60 real estate companies<sup>1</sup> have set near-term scope 3 reductions targets for 2030

Note: 1 \*Demand for low embodied carbon offices based on expected floorspace demand from corporate who have set SBTs before Q1 2023; 2 Real Estate companies who set SBTs are a mix of investors, property developers and other companies involved in the sector. Sources: JLL (2023); SBTi (2023) Target Dashboard; Systemiq Analysis; Choice Properties (2022) Environmental, Social & Governance Report; Hulic (2020) Environmental Performance Data ; Icade (2022) Climate Report March 2022

# But demand signals for low embodied carbon buildings remain very low; regulation may be required to help drive action



## Good performance not yet reflected in asset valuation

- Only few transactions of low EC buildings to date therefore **little evidence that low EC drives higher exit value yet**

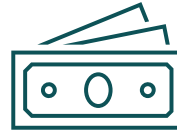

## Lower EC development do not yet attract lower cost of capital

- **Cost of capital** mainly linked to certification schemes today
- Given certifications not yet reflecting good EC performance → **low EC buildings do not yet attract lower cost of financing**



## Signals from the rental market not yet attractive

- There is **little evidence yet that tenants are willing to pay rent premiums** for lower embodied carbon buildings



# Regulation in developed economies is in the early stages, with some mandatory lifecycle assessments; some is beginning to set limits on emissions

## From voluntary reporting standards...



PCAF developed guidelines for measuring & disclosing GHG emissions associated with lending & investment activities

### Guidance for Financial Institutions (published)

### Existing assets & new development

	Upfront (A1 – A5)	Optional but strongly recommended
Embodied carbon	Use stage (B1-B5)	Mandatory <sup>1</sup>
	End-of-life (C1-4)	Not covered
	Beyond lifecycle (D)	Not covered
Operational carbon	Energy use (heating and electricity) (B6)	Mandatory <sup>2</sup>



EC reporting **mandatory for first owners** (i.e., buyer of new development) but optional for subsequent (i.e., buyer of existing asset)



SBTi reporting guidance builds on PCAF and UKGBC

## ... to new regulation

An increasing number of countries are **mandating life cycle assessment (LCAs)** and progressively setting up **carbon limits** for new buildings

Jurisdiction	Regulation description	Status	Intro.
<b>LCA requirement</b>			
Belgium	National LCA for state government buildings	Mandatory	In force
Germany	National LCA for federal government buildings	Voluntary	In force
Canada	National LCA for federal buildings, <b>limit by 2025</b>	Mandatory	In force
Sweden	Carbon reporting for new buildings, <b>limits by 2027</b>	Mandatory	In force
Vancouver	LCA reporting for all buildings, <b>limits by 2030</b>	Mandatory	In force
<b>Embodied carbon limits on buildings</b>			
France	National lifecycle limits on new buildings	Mandatory	In force
Denmark	National lifecycle limits on new buildings	Mandatory	2023
Finland	National lifecycle limits on new buildings	Mandatory	2025
New Zealand	National lifecycle limits on new buildings	Mandatory	Open
Netherlands	National lifecycle limits for new buildings	Mandatory	In force
Minnesota	State-funded projects must reduce impacts by 10%	Mandatory	In force
<b>Other</b>			
California, US	Placing limits on certain materials for state agencies	Mandatory	In force
EU	Sustainable finance taxonomy for large buildings	Voluntary	In force
United States	Materials LCA requirement for federal buildings	Mandatory	Open

Notes: 1 In order to guarantee a net positive environmental benefit of a retrofit, it is imperative to ensure that the embodied carbon emitted as a consequence of the retrofit is considered in addition to the reduction in operational emissions; 2 Emissions resulting from owner-controlled spaces must be separated from tenant-related building emissions. Both are mandatory to report; UKGBC stands for UK Green Building Council and is a membership-led industry network part of the World Green Building Council driving sustainability agenda in the Built Environment sector. Sources: PCAF (2022), *Accounting and reporting of financed GHG emissions from real estate operations*; UKGBC (2019), *Guide to Scope 3 Reporting in Commercial Real Estate*

# Setting clear embodied carbon limits is challenging given a lack of data and inconsistencies in reporting; even building certification schemes struggle to develop criteria

1

**Supply chain complexities:** Building materials often come from global supply chains, making it challenging to trace the carbon emissions data associated with each product's production and transportation

2

**Lack of LCA measurement standards:** Without standardized assessment methods, it is difficult to make informed decisions and compare the carbon impacts of various design options

3

**Certifications not fit-for-purpose:** green certification schemes do not yet drive reduction in embodied carbon in buildings



## LEED Green Rating & Certification scheme

- **LEED is a green building certification program** used worldwide with highest number of LEED-certified buildings in the US.
- It includes a set of rating systems for the **design, construction, operation, and maintenance** of green buildings
- **Only 5 out of 110 points in LEED certification cover building lifecycle impact**, (i.e. embodied carbon)
- Therefore, LEED top rating (i.e. platinum) **can be achieved without addressing embodied carbon at all**



# Regulation needs to differentiate for different types of buildings and should focus on lifecycle emissions to prevent unintended consequences for operational energy

## Embodied carbon average limit in France

Kg CO2/m2 over full building lifecycle

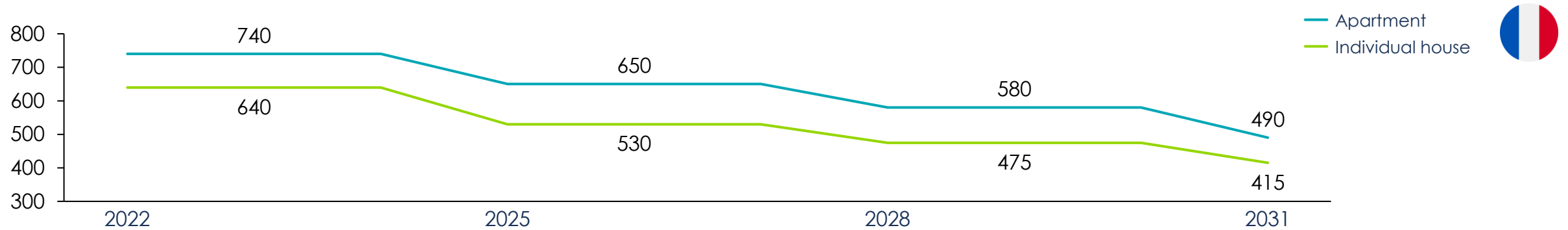

## Whole-life carbon minimum requirements in Denmark

Kg CO2/m2/year (assuming 50-year lifecycle)

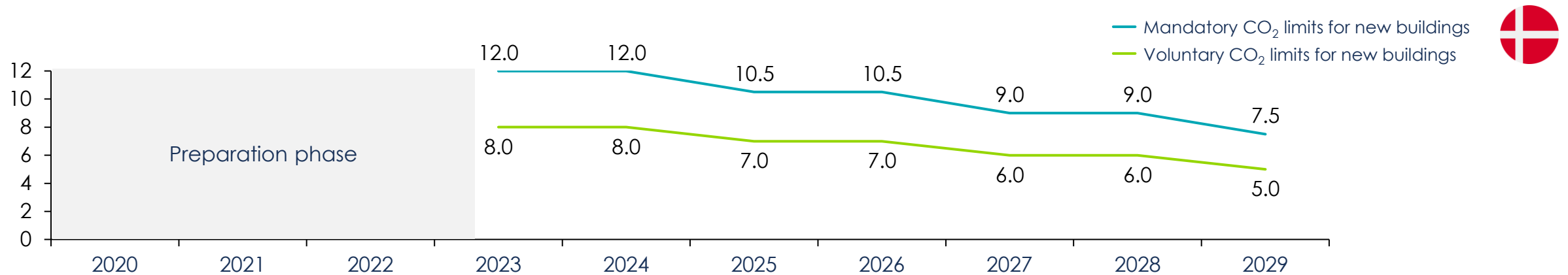

Note: The carbon limits for Denmark comprise both embodied and operational carbon emissions based on life-cycle analysis, as opposed to only embodied for France  
 Sources: Ministère de la transition écologique (2018) RE2020: eco-construire pour le confort de tous for France and Ministry of Interior and Housing (2021) National Strategy for sustainable construction

# Regulating minimum kgCO<sub>2</sub>/m<sup>2</sup> is much harder than kWh/m<sup>2</sup>, but there are clear things that regulation and policy can do to drive a greater focus on embodied carbon

## Challenges to regulating embodied carbon:

- Different types of buildings will have different embodied carbon requirements (e.g., structural considerations beyond a developer's control)
- Trade-offs with operational carbon, durability, safety
- Risk that poorly designed regulation is a barrier to innovation

→ Very hard to have a simple metric such as kWh/m<sup>2</sup> for operational carbon

## Regulation should focus on:

- Mandating minimum carbon intensity requirements for material inputs
- Mandating a minimum recycled content for material inputs
- Requirements for lifecycle carbon assessments (e.g., to overcome trade-offs between operational and embodied carbon)
  - Clear reporting frameworks
  - Disclosure

## Other key policies and incentives:

- Skills, training and guidance for low embodied carbon building
- Sharing of best practice
- Data sharing



# Next steps



## Next steps

- Refinement of numbers and conclusions in this deck
- Synthesis of key messages and story across the whole workstream
- Report drafting over the summer
- Final workshop to present report in September
- Member review of report in September





# Energy Transitions Commission

The Energy Transitions Commission is hosted by SYSTEMIQ Ltd.

© 2022 SYSTEMIQ Ltd. All rights reserved.

This is an internal document which provides confidential advice and guidance to partners and staff of SYSTEMIQ Ltd. and its subsidiaries. It is not to be copied or made available to any other party without prior written approval.